



Product Information
Version 2.0

ZEISS LSM 880 with Airyscan

Your New Standard for Fast and Gentle Confocal Imaging



Your New Standard for Fast and Gentle Confocal Imaging

- › In Brief
- › The Advantages
- › The Applications
- › The System
- › Technology and Details
- › Service

To get ahead in your research you may want to image the smallest structures, catch the faintest signal or track the fastest processes – or do all of that at once. When it comes to getting accurate data from live cells or other weakly-labeled samples, there is no such thing as too much sensitivity, resolution or speed. Each photon of emission light is precious. With Airyscan you have the unrivaled combination of fast superresolution and sensitive confocal image acquisition at hand. Use multicolor samples with any label and get image quality like you've never seen before. Decide for this novel detector design and get a 4-8× improvement in signal-to-noise ratio (SNR) as compared to imaging with conventional confocal GaAsP detectors. And 1.7× higher resolution for your single photon or multi-photon experiments. The choice is yours.

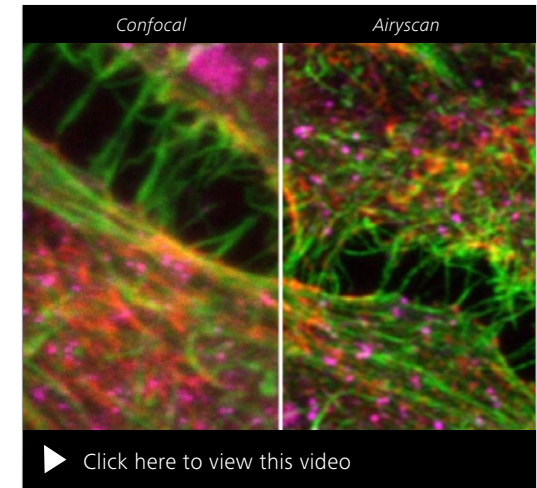

HeLa cells stained for Actin (green), Adapter Protein AP-3 (magenta) and Septin A (red). Courtesy of S. Traikov, BIOTEC, TU Dresden, Germany

See for yourself how Airyscan gives you better data than ever before. Book a hands-on demonstration in one of our ZEISS Microscopy Labs now. >> www.zeiss.com/lsm880

Simpler. More Intelligent. More Integrated.

- › In Brief
- › **The Advantages**
- › The Applications
- › The System
- › Technology and Details
- › Service

Airyscan: Enter a New World of Confocal Performance

Imagine a true confocal that will give you high sensitivity and improved resolution in x, y and z, and then combine this with high speed – all in a single system. With Airyscan you will be increasing the resolution of your imaging far beyond that of a classic confocal point scanning microscope. You can resolve 140 nm laterally and 400 nm axially, at 488 nm – without sacrificing sensitivity. Airyscan in Fast mode gives you the high acquisition speed, sensitivity and superresolution you need to answer your scientific questions.

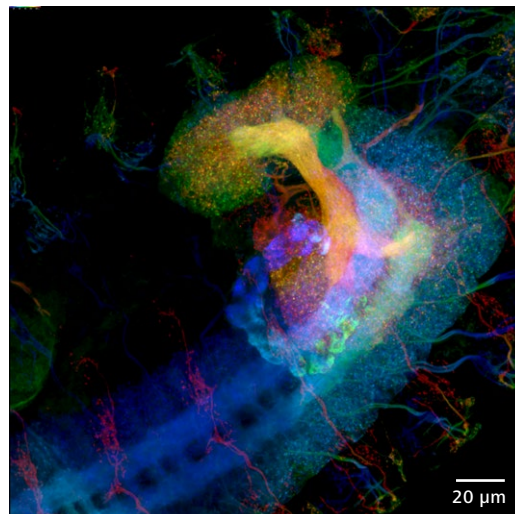

Drosophila embryo. Color coded maximum intensity projection of the central nervous system. Courtesy of J. Sellin, AG Hoch, LIMES Institute, Bonn, Germany

Perform Quantitative Imaging

Scientific results depend on unbiased data. LSM 880 guarantees gentle imaging of your sample through homogeneous illumination, combining linear scanning with a sensitive detection infrastructure. Working with identical pixel times and continuous scanner monitoring, you can perform quantitative imaging at all speeds and scan modes. Get robust and reliable results, even from your most demanding single molecule imaging and analysis.

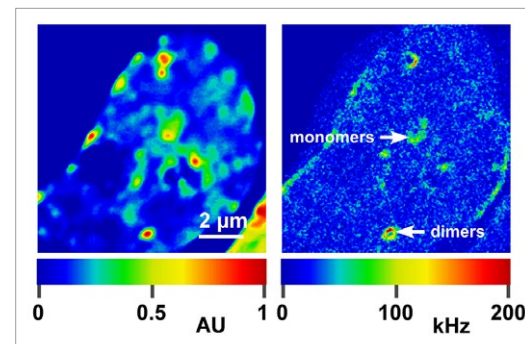

Heterochromatin protein 1 (HP-1) fused to GFP and expressed in the nucleus of a human Hep G2 cell.

Left panel shows the distribution of HP-1 between Euchromatin and denser Heterochromatin areas.

Right panel represents a brightness map demonstrating dimerization of HP-1 within heterochromatic regions.

Sample: courtesy of P. Hemmerich, Leibniz-Institute for Age Research (FLI), Jena, Germany

Increase Your Productivity

Save time on investigations into localization and interaction of proteins that require multiple fluorescent labels. LSM 880 collects all these signals in one go, with high speed and high sensitivity. You perform simultaneous spectral detection in a single scan with the highest number of descanned or non-descanned channels – featuring GaAsP technology, too. LSM 880 lets you take full advantage of large fields of view and the highest speed of any linear scanning confocal – up to 13 fps.

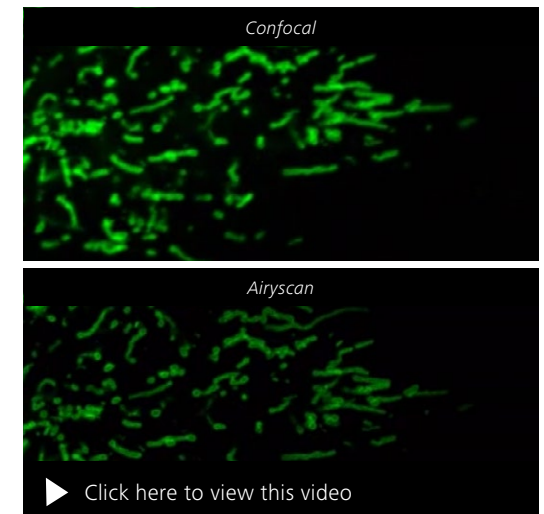

Mitochondria, RK 13 TOMM20 labeled with Cerulean 3; comparing confocal GaAsP and Airyscan detection. Sample: courtesy of M. Davidson, The Florida State University, Tallahassee, USA

Your Insight into the Technology Behind It

- › In Brief
- › **The Advantages**
- › The Applications
- › The System
- › Technology and Details
- › Service

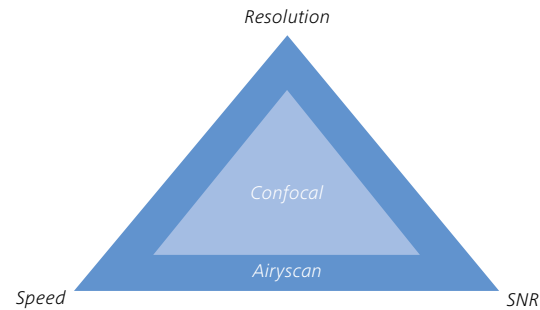
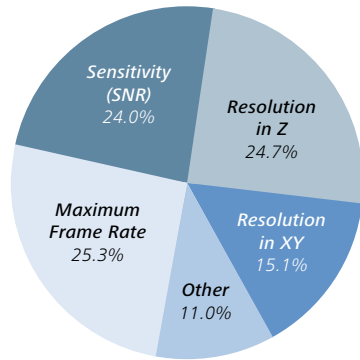

A survey among 250 researchers working with confocal microscopes revealed that their imaging would benefit most from an increase in sensitivity, resolution and speed.

Airyscan extends exactly those parameters for your experiments and high speed acquisition combined with increased resolution and signal-to-noise-ratio (SNR).

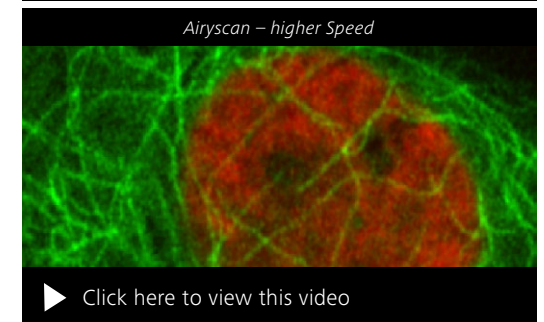
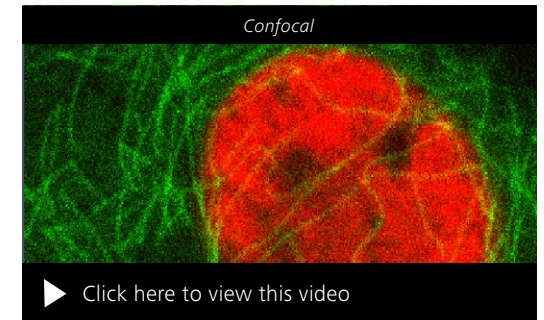
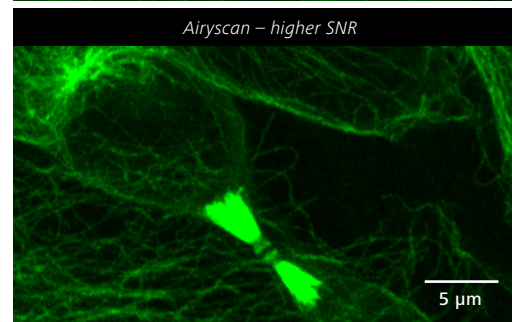
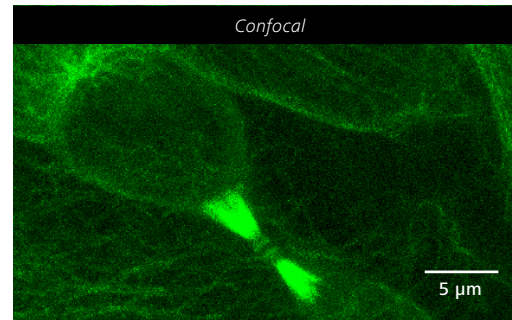
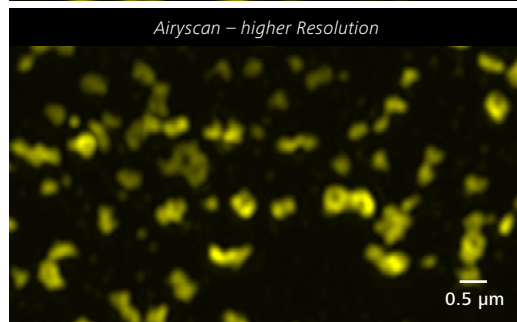
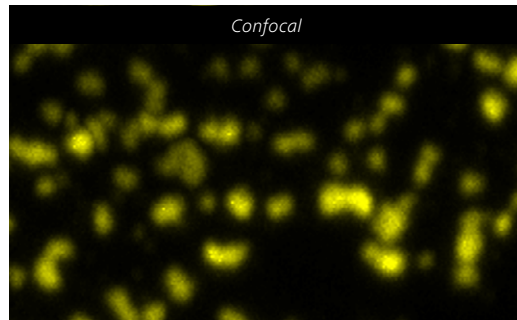

Your Insight into the Technology Behind It

- › In Brief
- › **The Advantages**
- › The Applications
- › The System
- › Technology and Details
- › Service

The Airyscan Principle

Airyscan is a detector that draws on the fact that a fluorescence microscope will image a point-like source as an extended Airy disk (Airy pattern). In a standard confocal microscope the out-of-focus emission light is rejected at a pinhole, the size of which determines how much of the Airy pattern reaches the detector. When you increasingly close the pinhole in a standard confocal microscope to reject out-of-focus light, you get a sharper image, but it's also dimmer since a great deal of light is then lost. The smaller the pinhole, the higher the resolution, but – equally – the greater the loss in light.

Airyscan solves this conundrum between resolution and light efficiency by imaging the Airy disk

onto a concentrically-arranged hexagonal detector array. Its detection area consists of 32 single detector elements, each of which acts like a very small pinhole. The confocal pinhole itself remains open and doesn't block light – thus all photons of the whole Airy disk are collected.

The signals from all detector elements are then reassigned to their correct position, producing an image with increased signal-to-noise ratio and resolution.

An area detector consisting of multiple detector elements allows great flexibility in imaging modes. In Fast mode, the excitation beam is elongated in y and the Airyscan detector, with just one horizontal scanner movement, acquires four lines of

image information instead of only one. This parallelization delivers a unique combination of high speed, high resolution and high sensitivity. Because it capitalizes on the scanning and optical sectioning capabilities of a confocal, Airyscan works with standard samples and standard dyes, and even with your thicker samples such as tissue sections or whole animal mounts that need a higher penetration depth.

Both in single and multiphoton excitation, it's up to you whether to use the advantages of Airyscan and the Fast module to get better signal-to-noise, superresolution or speed.

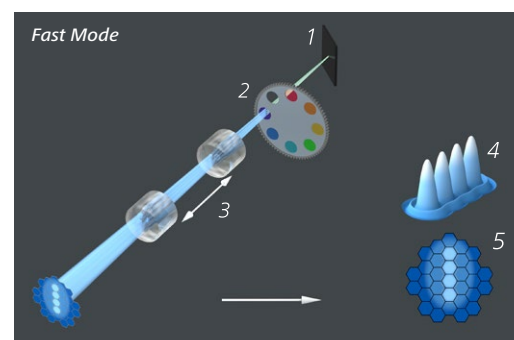
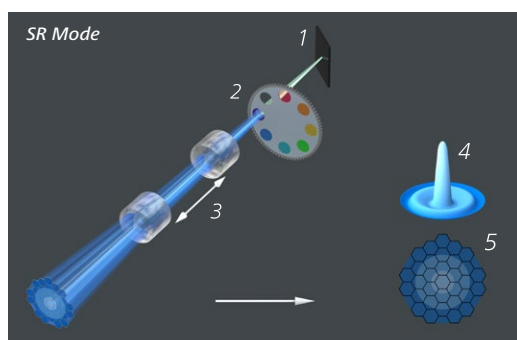

Schematic beam path of Airyscan (1. Mirror, 2. Emission filters, 3. Zoom optics, 4. Airy disk, 5. Airyscan detector)

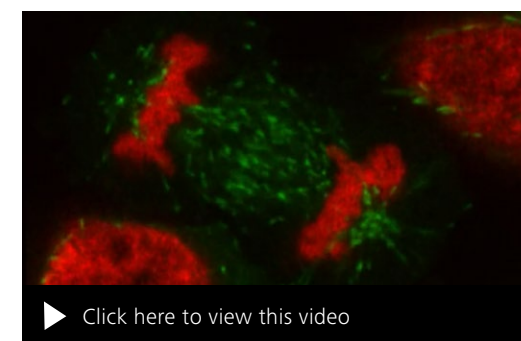

Mitosis of HeLa Kyoto cells. Red: H2B labelled with mCherry, green: microtubule end-binding protein labelled with GFP. Courtesy of J. Ellenberg, EMBL, Heidelberg, Germany

Your Insight into the Technology Behind It

- › In Brief
- › **The Advantages**
- › The Applications
- › The System
- › Technology and Details
- › Service

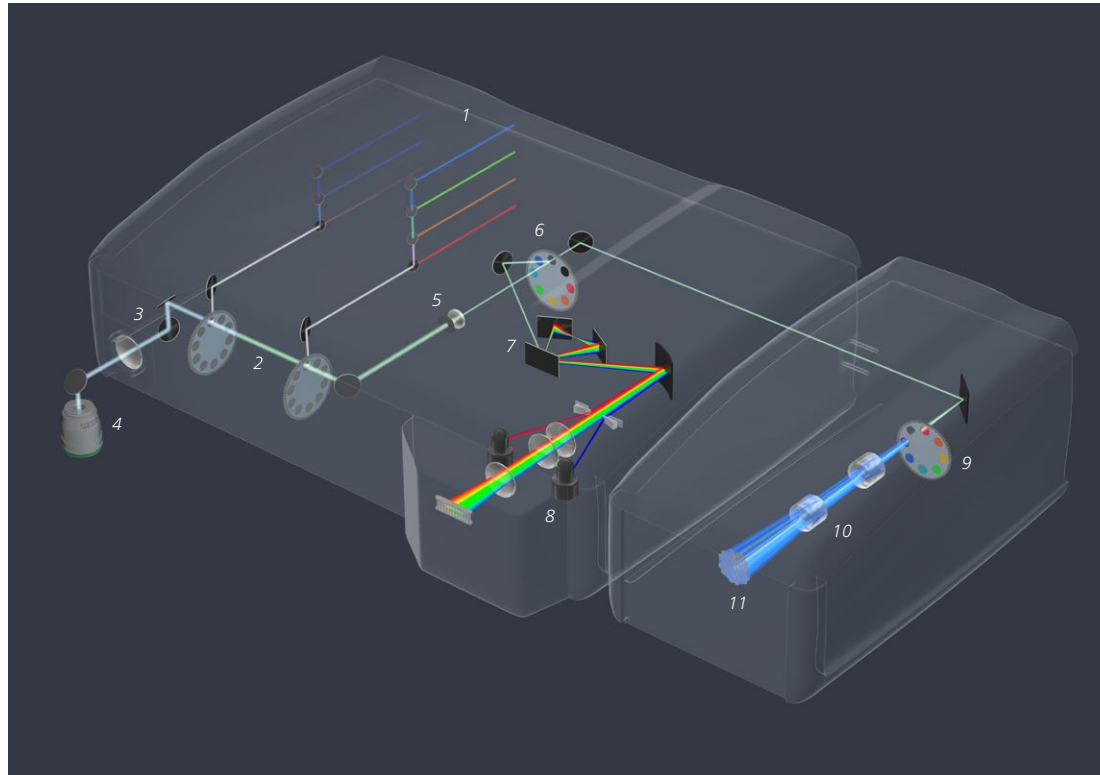

- | | | | |
|----------------------------------|-------------------------------|-----------------------------|-----------------------|
| 1. Excitation laser lines | 3. Galvo scanning mirrors | 6. Secondary beam splitters | 9. Emission filters |
| 2. Twin Gate main beam splitters | 4. Objective | 7. Recycling loop | 10. Zoom optics |
| | 5. Pinhole and pinhole optics | 8. Quasar detection unit | 11. Airyscan detector |

Beam path of LSM 880 with Airyscan

Emission light travels through the Twin Gate main dichroic beam splitter with its very efficient laser suppression to deliver supreme contrast. Then, at the secondary beam splitter, all emission light either travels via the recycling loop to the internal spectral detection unit (Quasar) with up to 34 channels. Or, light is sent to the revolutionary Airyscan detector with GaAsP technology.

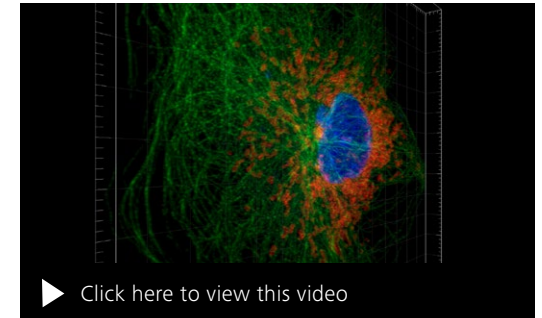

African green monkey kidney. TOMM20 (Alexa 568, red), Tubulin (Alexa 488, green) and nucleus (DAPI, blue). Sample: courtesy of M. Davidson, The Florida State University, Tallahassee, USA

Your Insight into the Technology Behind It

- › In Brief
- › **The Advantages**
- › The Applications
- › The System
- › Technology and Details
- › Service

Fast and Linear Scanning – Your Powerful Combination

To fully resolve the movement of labeled proteins in dynamic cellular and subcellular processes you often need to image at around 10 frames per second. Now, with LSM 880, you can achieve up to 13 frames per second at 512×512 pixels. Add Airyscan with the Fast module to image with up to 27 frames per second and twice the pixel time at 480×480 pixels.

While you're performing unidirectional or bidirectional scanning, LSM 880 is constantly monitoring and calibrating the scanner position. This guarantees a stable field of view and equal pixel integration times over the whole field of view. Linear scanning is an essential prerequisite for your quantitative and correlative imaging. It gives you a constant signal-to-noise level and uniform exposure to the illuminating laser throughout the scanned area, including manipulated regions of interest. Unlike traditional sine scanning confocals, LSM 880 uses more than 80% of the scanning time for data acquisition. That means you will enjoy a 29% improvement of signal-to-noise ratio because of longer pixel integration times at a defined frame rate. You can't always influence the orientation of your structure of interest as regards to the detection optics, but with LSM 880 you can always adapt the scanfield and rotate it freely to best suit your sample.

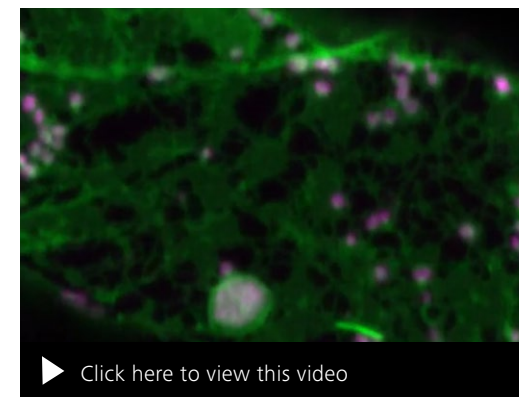

Arabidopsis root. Green: endoplasmic reticulum labelled with GFP, Magenta: Golgi labelled with RFP. Maximum intensity projection of z-stack with 8 slices in Nyquist sampling. Courtesy of C. Hawes, Oxford Brookes University, UK

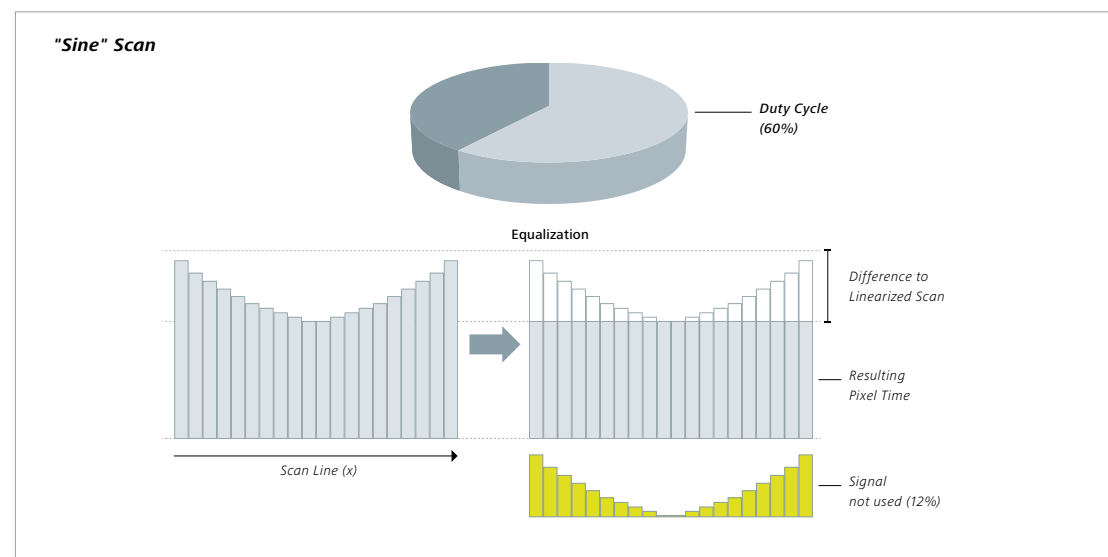
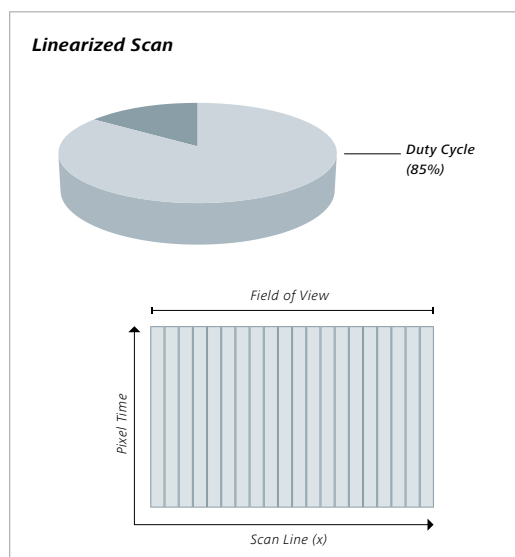

Your Insight into the Technology Behind It

- › In Brief
- › **The Advantages**
- › The Applications
- › The System
- › Technology and Details
- › Service

Parallel Acquisition of Multiple Channels

It takes multiple labels to analyze interactions between different cellular or subcellular structures, but you can achieve the highest timing precision and speed up your imaging time by recording their intensities simultaneously. LSM 880 lets you acquire the entire spectrum – and all your labels – in just one scan with 32 channels, 512 × 512 pixels at 5 frames per second.

Set up 10 channels for multichannel spectral imaging and then add the transmission detector. You can now image all fluorescent dyes and the additional oblique contrast in a single scan. This protects your sample and also saves you time.

Especially for your demanding multiphoton experiments, you will profit from having this fundamental capability: up to 12 non-descanned detectors can be read out in parallel.

GaAsP detectors have proven to be the best choice for confocal imaging of weak fluorescent signals. In photon counting mode you can use them for single molecule techniques such as fluorescence correlation spectroscopy (FCS) and cross correlation spectroscopy.

Benefit from the Most Spectral Confocal

Investigations into localization and interaction of proteins often require multiple fluorescent labels. Now you can save time and collect all these signals in one go, with high speed and high sensitivity. LSM 880 lets you perform spectral detection with any number of descanned or non-descanned channels in a single scan.

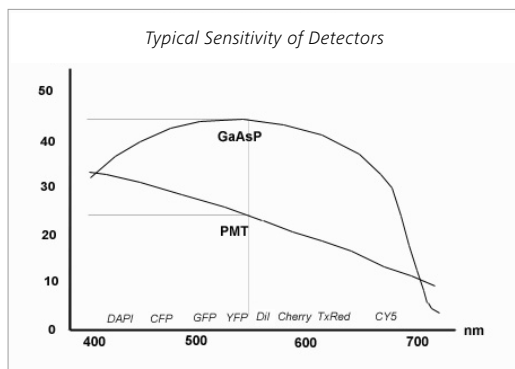

Typical spectral quantum efficiency (QE) of PMT and GaAsP detectors

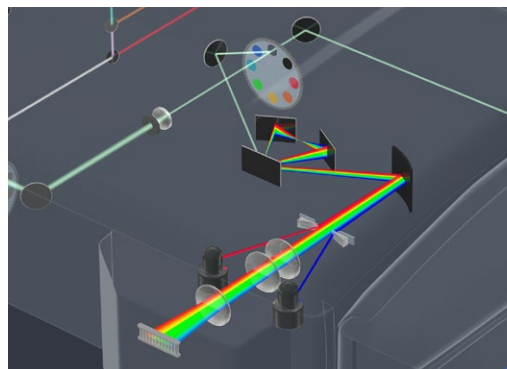

Spectral detection unit of LSM 880

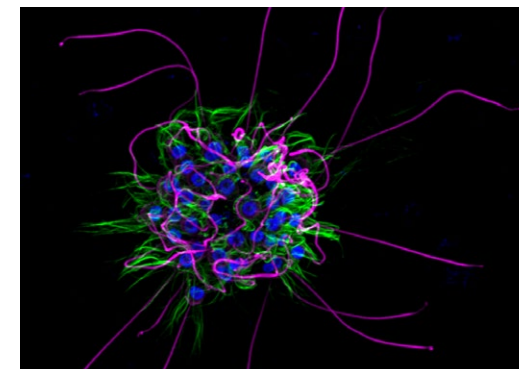

Choanoflagellate rosette colony. Blue: nuclei stained with Hoechst; magenta: tubulin of the flagella and cell body; green: actin microvilli collars stained with phalloidin. Courtesy of H. Aaron, UC Berkeley, USA

Expand Your Possibilities

- › In Brief
- › **The Advantages**
- › The Applications
- › The System
- › Technology and Details
- › Service

Experiment Designer: Your Smart Automation Module for Enhanced Productivity

Sometimes your applications require complex acquisition strategies. Especially for statistical analysis, repetitive imaging of a large number of samples with different imaging set ups comes into play. Experiment Designer is an easy-to-use module for ZEN imaging software that sets up your imaging for multiple positions, using the large number of imaging modalities of LSM 880. It is complemented by a number of hardware and software options so your sample always stays in focus, even during the most demanding long-term time lapse experiments.

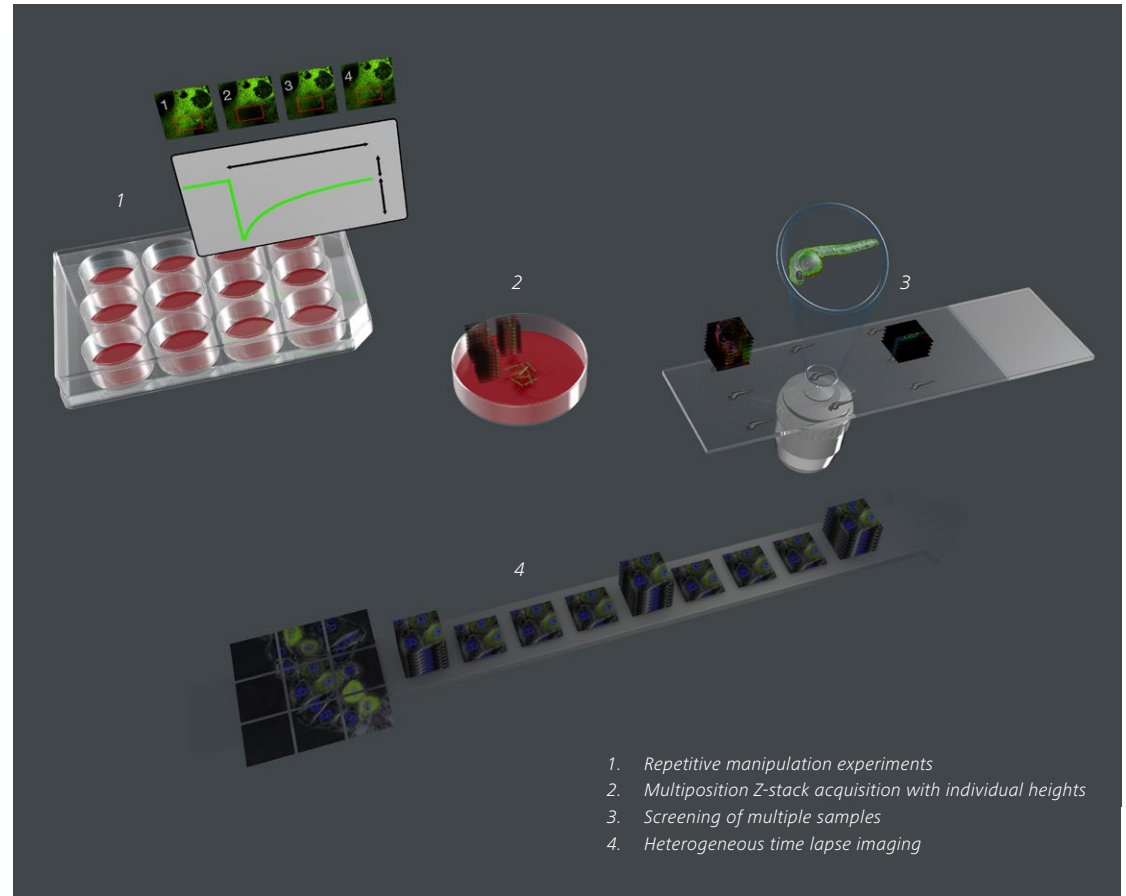

With the ZEN software module Experiment Designer you can set up complex imaging routines consisting of freely defined and repeatable experiment blocks with multi-position tile scans of multichannel Z-stacks.

Expand Your Possibilities

- › In Brief
- › **The Advantages**
- › The Applications
- › The System
- › Technology and Details
- › Service

Multiphoton Microscopy

Multiphoton microscopy lets you acquire optical sections of deep tissue layers. This imaging method makes use of these basic principles:

- The longer the wavelength of light, the less it is scattered when entering tissue. Light of a wavelength between 600 and 1300 nm experiences the lowest absorption in tissue, making it nearly transparent in this spectral range.
- A fluorescent dye with an excitation maximum at 500 nm can be excited with one photon of this wavelength or with two photons of the doubled wavelength –1000 nm – that arrive simultaneously.
- A powerful pulsed tunable laser of 700-to-1300 nm makes sure that enough photons arrive simultaneously to excite the fluorescent dye. Outside the focal plane, the laser intensity drops exponentially and produces no emission light.

Emission light, created by multiphoton excitation, can be captured efficiently with non-descanned detectors. Using Airyscan detection with multiphoton excitation combines deep tissue penetration with increased sensitivity, resolution and speed.

You can make use of these Airyscan advantages for functional imaging experiments, large volume imaging and screening applications.

Even non-stained structures can be visualized with multiphoton high intensity excitation by the nonlinear effect of frequency doubling. This second harmonic generation (SHG) on non-centrosymmetric molecules with predominantly periodic alignment occurs, for example, in striated muscle and collagen.

The nonlinear effect of frequency doubling (SHG) on non-centrosymmetric molecules with predominantly periodic alignment occurs, for example, in striated muscle and collagen.

Combine 3D Airyscan imaging with gentle multiphoton excitation and profit from increased sensitivity and resolution.

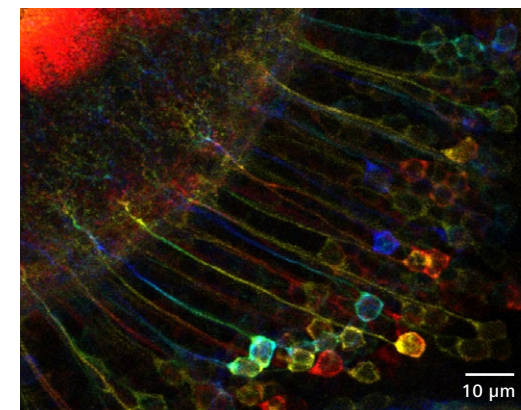

Zebra fish. Color coded maximum intensity projection of a 100 μm z-stack with 200 slices. Courtesy of C. Oldfield, UC Berkeley, US

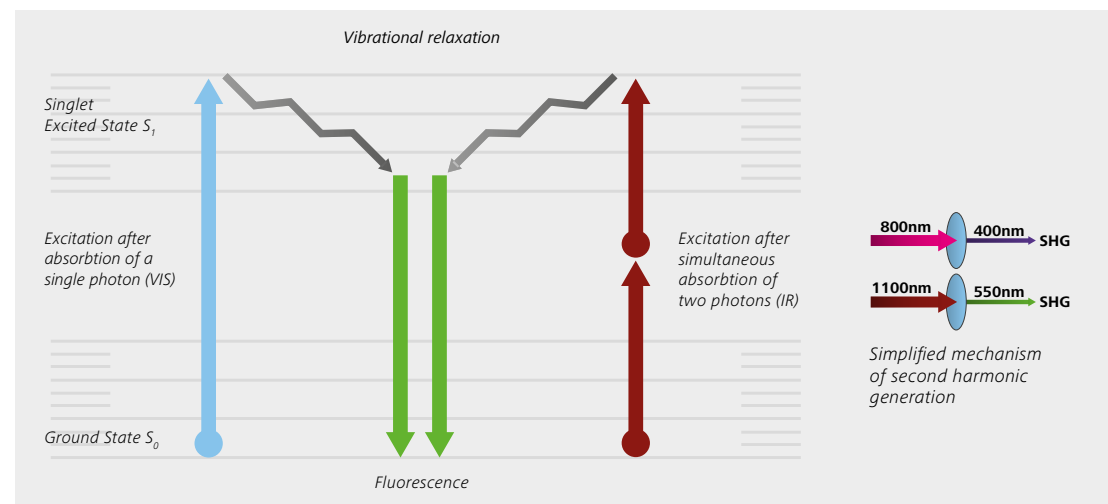

Energy diagram of 2 Photon Microscopy

Expand Your Possibilities

- › In Brief
- › **The Advantages**
- › The Applications
- › The System
- › Technology and Details
- › Service

Superresolution Microscopy

LSM 880 is the only confocal laser scanning microscope that can be combined with three complementary superresolution techniques in one system, delivering true multimodal imaging of your samples. Your LSM 880 with Airyscan can deliver resolutions down to 140 nm laterally and 400 nm axially even in thicker and denser samples. Acquire even smaller structures by combining it with ELYRA, the dedicated superresolution system for structured illumination (SR-SIM) and photoactivated localization microscopy (PALM). SR-SIM works best with thinner, less scattering samples and delivers large fields of view with a resolution down to 120 nm laterally and 350 nm axially. PALM uses photo-switchable fluorescent molecules, recording them over time and then superimposing these data. This lets you achieve resolutions down to 20 nm laterally and 50 nm axially.

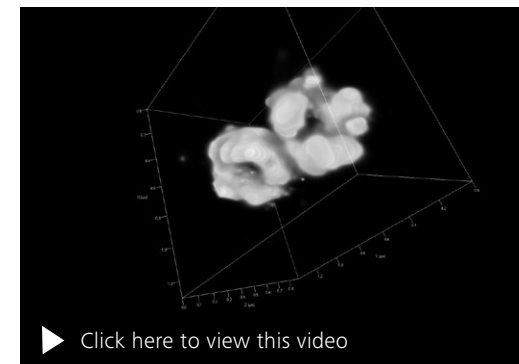

U2OS cell (human Osteosarcoma cell). CEP152, a centriolar protein (labeled with Alexa 647 conjugated antibodies); ELYRA 3D-PALM acquisition with 10 ms / frame. Courtesy of T. Klein and M. Sauer, University of Würzburg, Germany

Expand Your Possibilities

- › In Brief
- › **The Advantages**
- › The Applications
- › The System
- › Technology and Details
- › Service

Clearing Methods

Tissue clearing opens up a new dimension of optical penetration depth into biological samples such as tissue sections, mouse brains, embryos, organs, spheroids or biopsies.

With Axio Examiner and special objectives such as Clr Plan-Apochromat 10x/0.5 nd=1.38, Clr Plan-Apochromat 20x/1.0 Corr nd=1.38 or Clr Plan-Neofluar 20x/1.0 Corr nd=1.45, you can look deep into tissue that has been treated with a respective clearing agent such as Focus Clear or Scale including modified versions thereof. Thus the tissue gets almost transparent and the objectives provide the matching refractive index to the immersion medium. Image up to six times deeper than with a multiphoton microscope and up to 60 times deeper than with a conventional laser scanning microscope.

Get ready to be impressed by the quality of structural information you retrieve from the deepest layers: expect a big push forward, especially in basic neurobiological research and mapping of neuron networks.

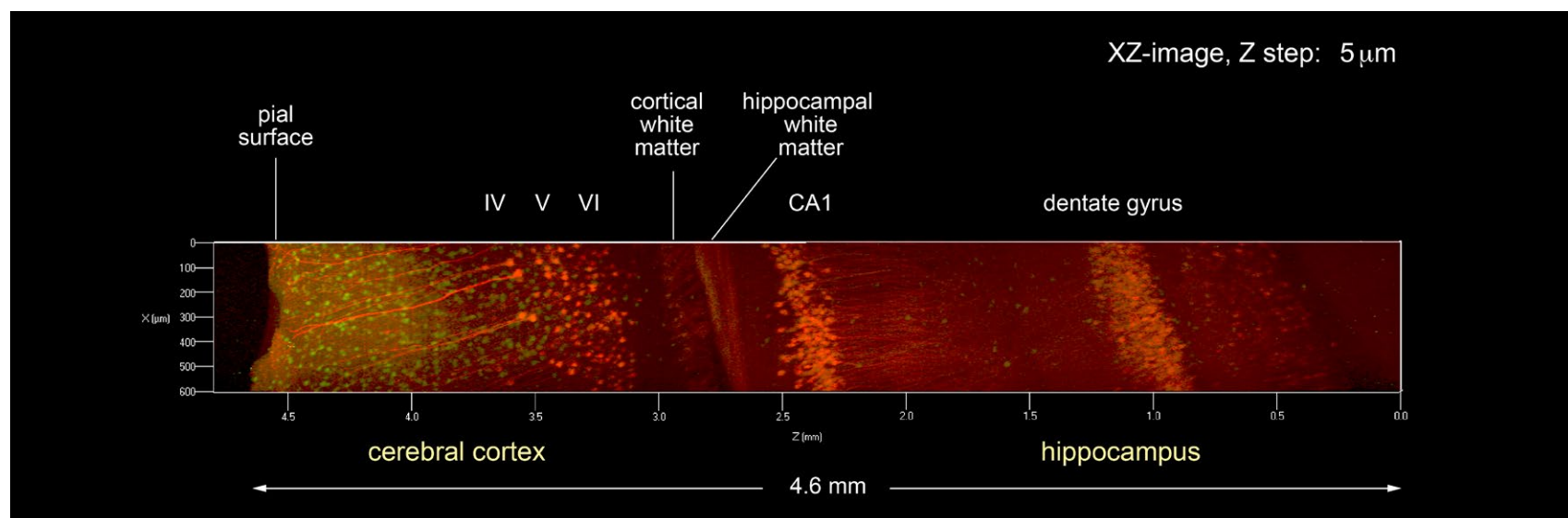
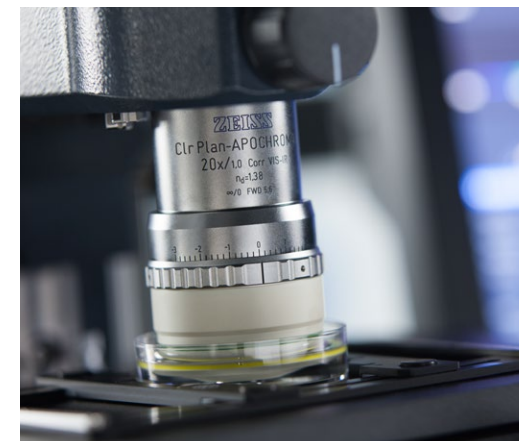

Maximum intensity projection, brain of 7-week old YFP-H mouse, fixed and cleared with Scale clearing technique (Hama et al, Nat Neurosci. 2011). Courtesy of H. Hama, F. Ishidate, A. Miyawaki, RIKEN BSI, Wako, Japan

Expand Your Possibilities

- › In Brief
- › **The Advantages**
- › The Applications
- › The System
- › Technology and Details
- › Service

As your needs grow, LSM 880 grows with you, forming the basis for a number of enhancements. Like every system from ZEISS, open interfaces and a modular architecture guarantee the seamless interaction of all components now and in the future. These include:



Combine Axio Observer.Z1 with integrated incubation modules, e.g. Incubator XL, to get the best tool for long term live cell imaging with stable temperature conditions.



The upright fixed stage microscope Axio Examiner.Z1 gives you ample specimen space and room for micromanipulation. This stable stand is ideally suited for multiphoton experiments with LSM 880. Combine the system with Airyscan or incubation for your demanding experiments with living specimens.



The upright research microscope Axio Imager.Z2 can be combined with LSM 880, Airyscan and incubation, too.



Airyscan can be added to any of the LSM 880 system configurations, including the version with BiG.2 detector.



Use BiG.2 with its two GaAsP detectors for FCS, photon counting experiments and FLIM on your LSM 880.



BiG.2 works perfectly as a non-descanned detector, also providing a highly sensitive direct coupled detector for FLIM.

Expand Your Possibilities

- › In Brief
- › **The Advantages**
- › The Applications
- › The System
- › Technology and Details
- › Service

As your needs grow, LSM 880 grows with you, forming the basis for a number of enhancements.

Like every system from ZEISS, open interfaces and a modular architecture guarantee the seamless interaction of all components now and in the future. These include:

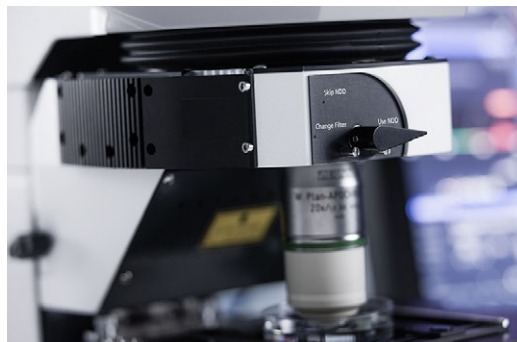

The two channel GaAsP NDD with flexible filter settings completes the ensemble of non-descanned detectors for Axio Examiner.Z1.



With Autocorr objectives and ZEN imaging software it's easy to adjust your microscope optics to your sample. You get crisp contrast and better signal to noise – even in your most challenging samples.



You can add a choice of cameras from the Axiacam series to LSM 880 for widefield imaging experiments – also in combination with LSM imaging.

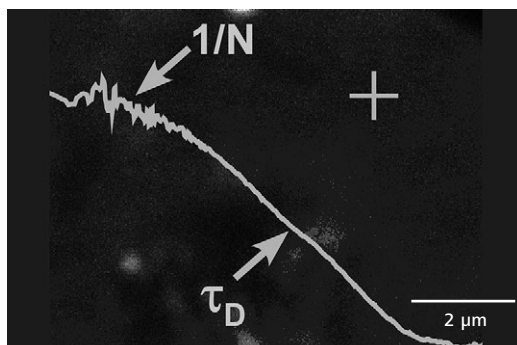

With the highly sensitive and stable GaAsP detectors of LSM 880 you easily perform Fluorescence Correlation Spectroscopy (FCS). You get information about the kinetics of single molecules.

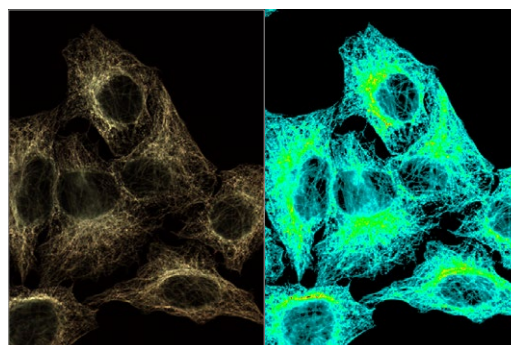

Förster Resonance Energy Transfer (FRET) and Fluorescence Recovery After Photobleaching (FRAP) are methods to study molecule interaction and motion.

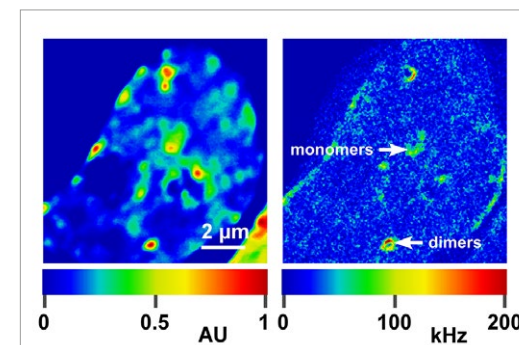

With the Number&Brightness analysis tool you evaluate the connection between the intensity in your sample and the number of molecules responsible for this signal intensity.

Expand Your Possibilities

- › In Brief
- › **The Advantages**
- › The Applications
- › The System
- › Technology and Details
- › Service



Enhance your Airyscan detector with the Fast module. It allows for highest imaging speed, combined with the superresolution and high SNR. Use this option for gentle live cell imaging of dynamic and functional processes.

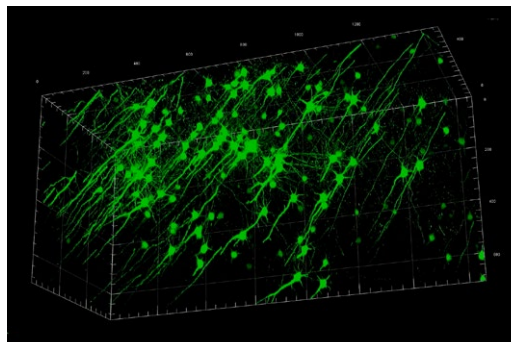

3Dxl Viewer – powered by arivis – is the new visualization module for ZEN imaging software. Render even large, super-resolution data sets acquired with LSM 880 and Airyscan. Create impressive 3D animations or fly-through videos to study your sample efficiently from all sides. (Sample courtesy of T. Ruff, Max Planck Institute of Neurobiology, Martinsried, Germany).



Shuttle & Find is your gateway to correlative light and electron imaging (CLEM). Combine the specificity of functional fluorescence imaging with ultrastructural information.



Definite Focus.2 compensates Z-drift and stabilizes the focal position of your sample. You can now perform long-term multi-position and tiling experiments that can last for multiple days.

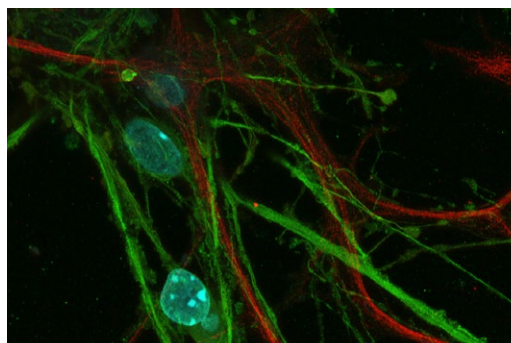

Collect all labels simultaneously with the numerous channels of LSM 880 and accelerate the deconvolution process significantly with the CUDA enabled GPUs. Add enhanced resolution and signal to noise to the multi-channel flexibility of imaging with LSM 880.

Tailored Precisely to Your Applications

- › In Brief
- › The Advantages
- › **The Applications**
- › The System
- › Technology and Details
- › Service

Typical Applications, Typical Samples	Task	ZEISS LSM 880 Offers
Antibody stained tissue slices	Document morphological relations of structures with a resolution of 140 nm (XY) / 400 nm (Z) at 488 nm excitation	Airyscan with GaAsP detector for superresolution imaging
Cleared tissue	Image cleared tissue with up to 5.6 mm in Z	Special objective corrected for immersion medium of refractive index 1.38 or 1.45 working with confocal or multiphoton imaging on Axio Examiner
Live cell culture	Study the motility of vesicles and organelles	Airyscan in Fast mode for gentle imaging with high frame rates
	Document the kinetics of endo- and exocytosis	Mixed mode imaging with LSM and superresolution based on photoactivated localization
	Screen and document cells expressing the desired fluorescent label in response to pharmacological treatment	Widefield imaging using AxioCam
Live cell culture with two labels	Study the motility of subcellular structures	Airyscan with GaAsP detector to image 2 colors with time lapse imaging in 2D or 3D at 2.5 frames per second and 9.6 frames per second with Fast mode.
	Explore the interaction of two proteins with fluorescent lifetime microscopy	BiG.2 as detector for FLIM and third party electronics and software
	Explore the interaction of two proteins exploiting the Förster Resonance Energy Transfer effect	FRET analysis tool
Live cells with multiple labels	Image over long time in an automated way	Experiment Designer software tool combined with spectral imaging
Fixed cell culture specimens	Document cellular structures in superresolution in 3D with about 2x the resolution of a confocal	Structured illumination with ELYRA
Live or fixed cells with multiple labels and overlapping emission signals	Examine the interplay of multiple proteins	Parallel acquisition of all signals with spectral imaging at 5 full frames per second and online or post processed unmixing
Cellular structures with weak labels	Image subcellular structures at physiological expression levels	Airyscan with GaAsP detector or LSM 880 with GaAsP detector
Living organisms/animals	See the interaction of cells within living tissue Imaging of live tissue with cells expressing multiple different fluorescent proteins	Multiphoton extension of LSM 880 Extension of LSM 880 NLO with second laser line for NLO*

(* available upon request)

Tailored Precisely to Your Applications

- › In Brief
- › The Advantages
- › **The Applications**
- › The System
- › Technology and Details
- › Service

Typical Applications, Typical Samples	Task	ZEISS LSM 880 Offers
Plant roots	Follow the changes of subcellular structures over time with a high resolution	Airyscan with GaAsP detector for superresolution imaging beyond 40 µm deep into tissue with up to 19 full frames per second (512 x 512 pixel) in Fast mode
Model organisms, e.g. Zebrafish, <i>Drosophila</i> or <i>C. elegans</i>	See fine details of the organisation and dynamics of endogeneously expressed FP proteins	Airyscan with GaAsP detector for superresolution imaging beyond 40 µm deep into tissue
Live samples with varying labelling intensities over the field of view	Collect all image information and decide on the way to present the best image in contrast later	Airyscan with GaAsP detector for imaging with 3 Airy units and the ability to virtually close the pinhole post-acquisition

ZEISS LSM 880 at Work

- › In Brief
- › The Advantages
- › **The Applications**
- › The System
- › Technology and Details
- › Service

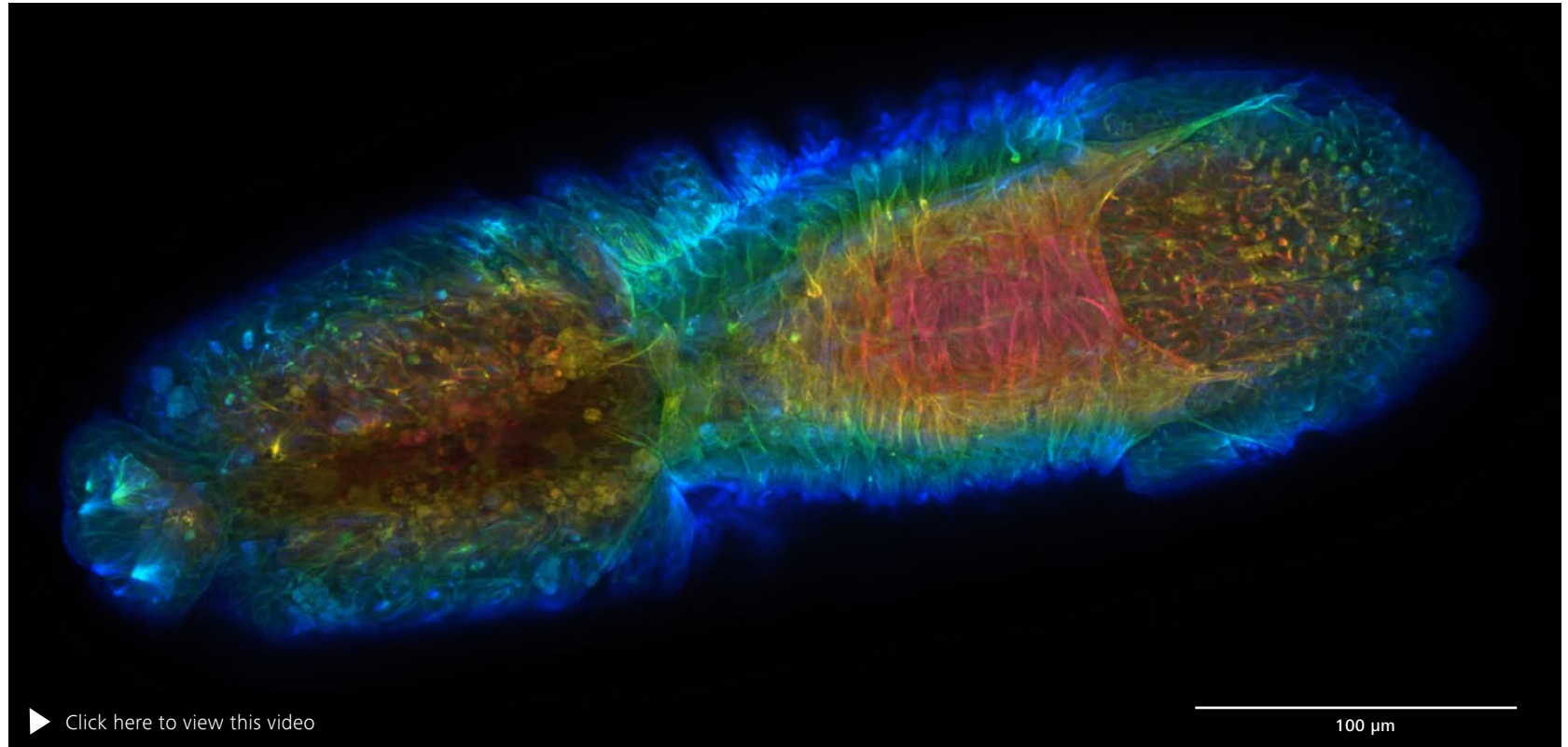

Drosophila embryo, depth coded maximum intensity projection. Microtubules labelled with GFP. Z-stack with 72 slices imaged for 11.5 h at 15 min interval. Airyscan in Fast mode. Courtesy of B. Erdi, Max F. Perutz Laboratories, University of Vienna, Austria

ZEISS LSM 880 at Work

- › In Brief
- › The Advantages
- › **The Applications**
- › The System
- › Technology and Details
- › Service

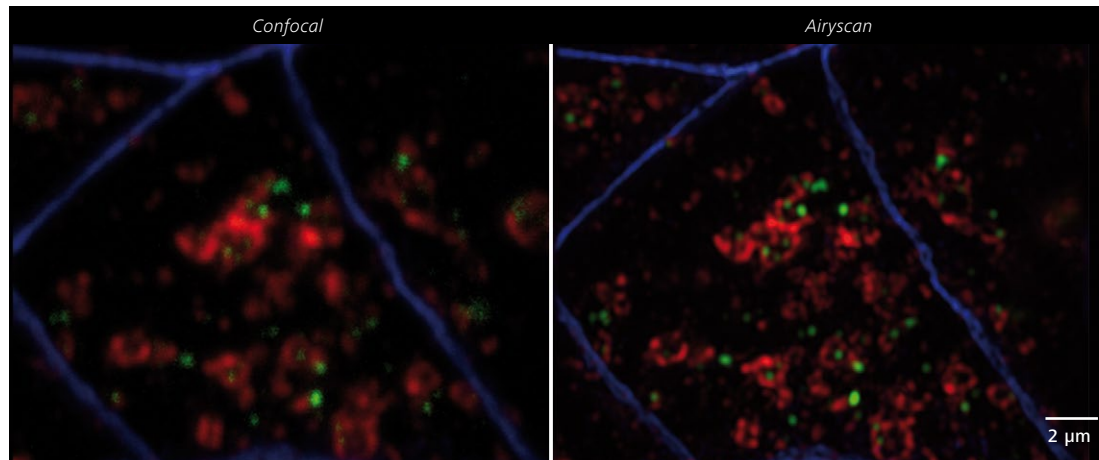

Human RPE cells, ZO1 (tight junction marker) in blue, photoreceptor outer segments stained with FITC in green, EEA1 (endosomal marker) in red. Courtesy of S. Almewadar, CRTD, TU Dresden, Germany

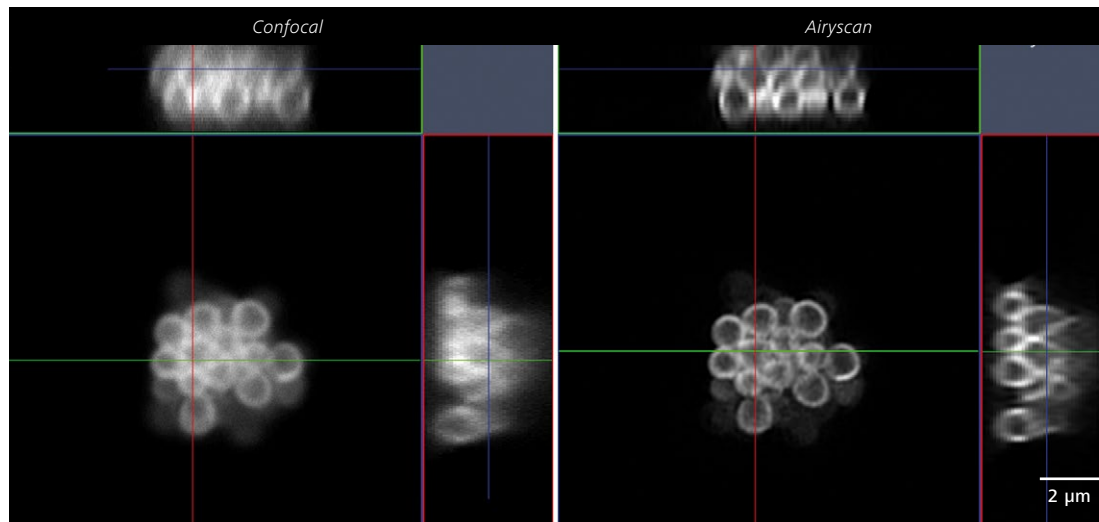

Fluorescent 1 µm ringbeads imaged at 488 nm

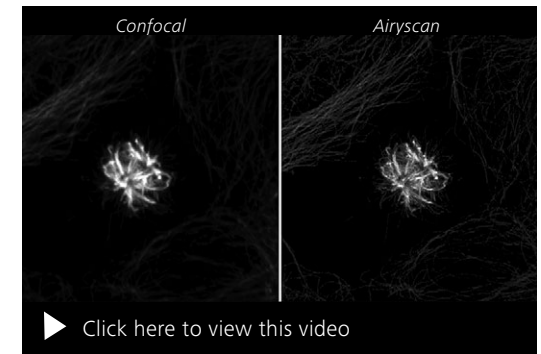

Fixed tumor cells, tubulin labelled with Alexa 555, Airyscan SR mode. Sample: courtesy of P. O'Toole and P. Pryor, University of York, UK

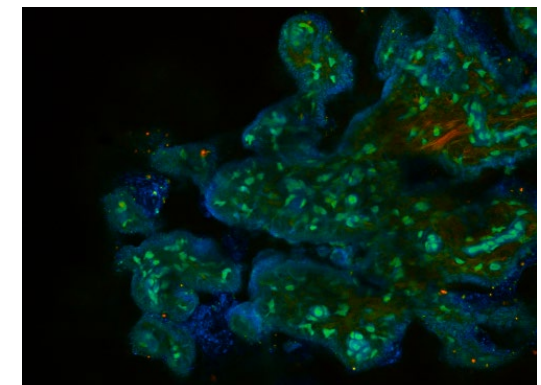

Skin tissue from pig labelled with Ethyleneblue. The unfixed sample was excited with 1100 nm using an OPO (optical parametric oscillator). Fluorescent lifetime measurement was performed using the detector module BiG.2 connected to the TCSPC electronics from Becker&Hickl. The color coded image shows the variation in lifetime within different types of skin cells.

ZEISS LSM 880 at Work

- › In Brief
- › The Advantages
- › **The Applications**
- › The System
- › Technology and Details
- › Service

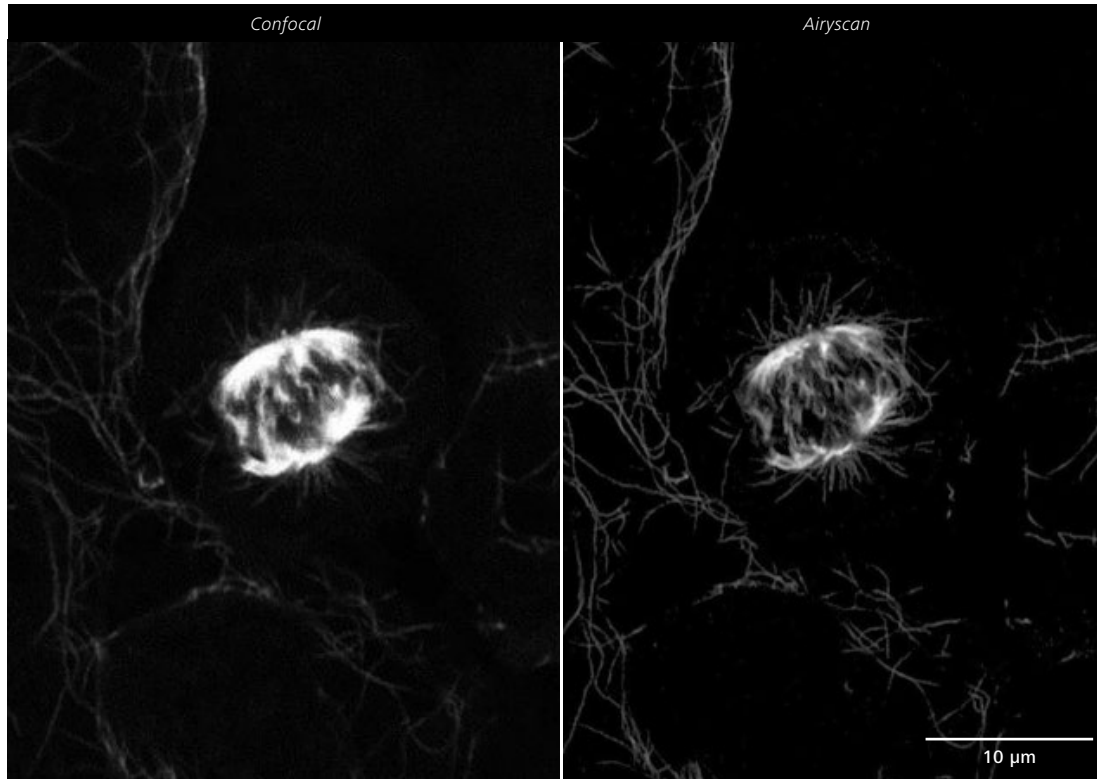

Fixed tumor cells, tubulin labelled with Alexa 555, Airyscan SR mode. Sample: courtesy of P. O'Toole and P. Pryor, University of York, UK

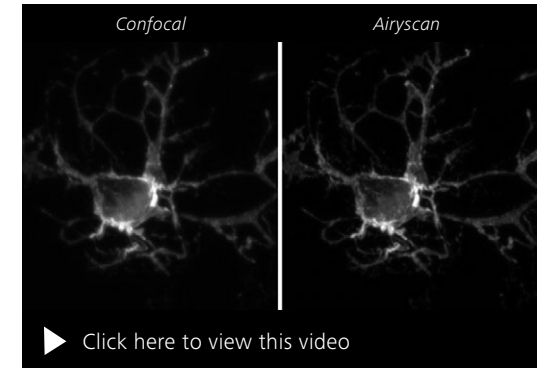

Oligodendrocyte, CNPase-antibody staining. Courtesy of C. Dornblut, Leibniz Institute for Age Research (FLI), Jena, Germany

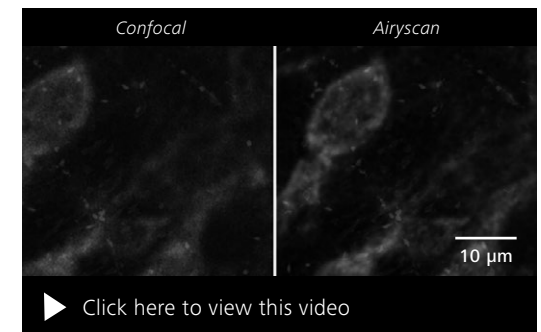

Slice of mouse brain, CNPase-antibody staining, imaged with 10x objective. Courtesy of C. Dornblut, Leibniz Institute for Age Research (FLI), Jena, Germany

ZEISS LSM 880 at Work

- › In Brief
- › The Advantages
- › **The Applications**
- › The System
- › Technology and Details
- › Service

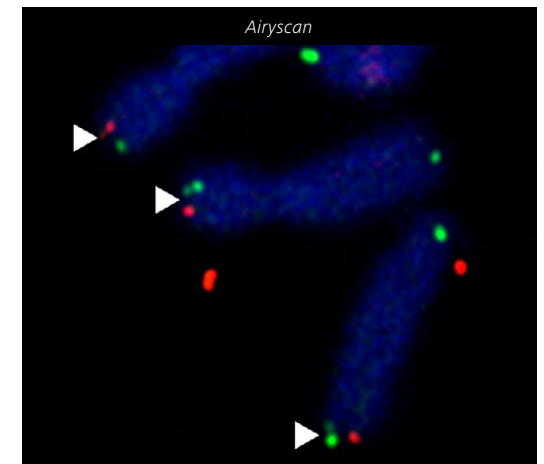
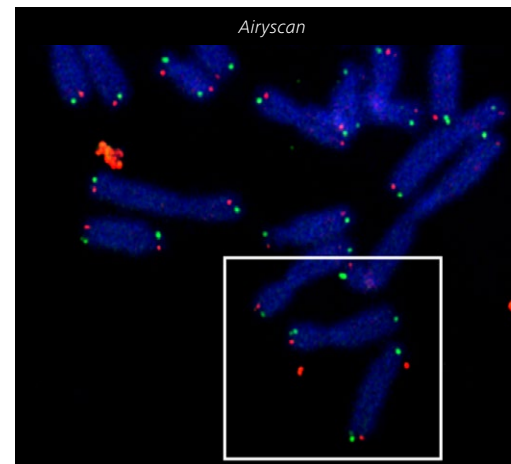
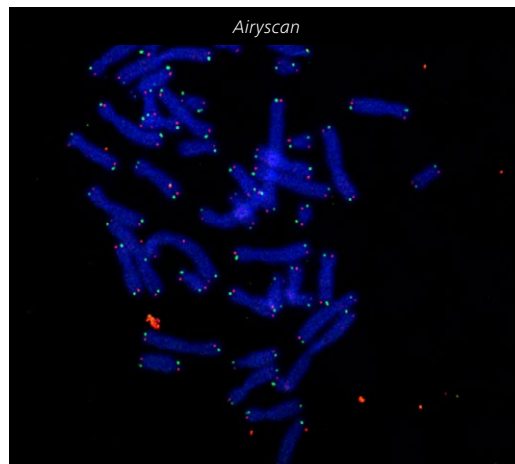
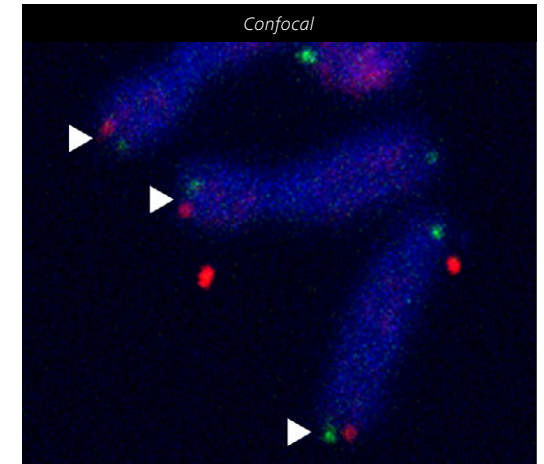
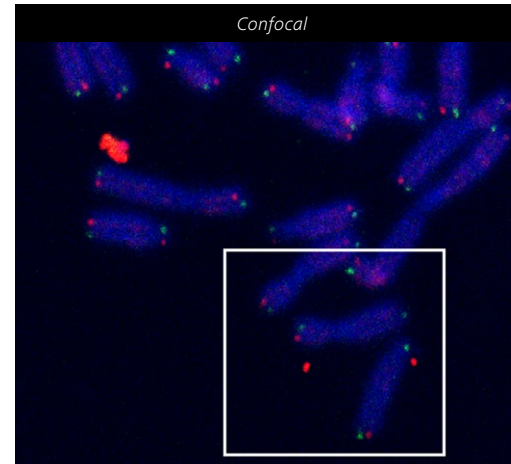
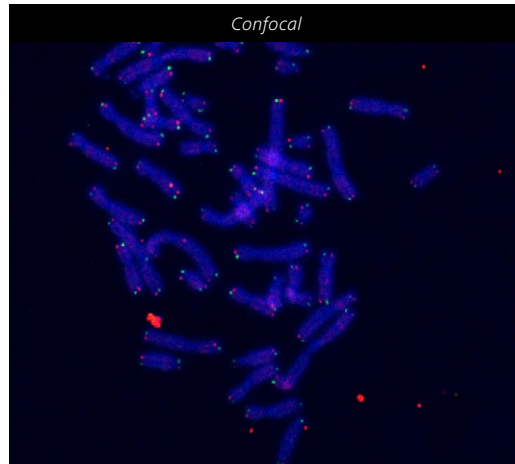

IMR90 human diploid lung fibroblasts. DNA has been stained with DAPI, the telomeric G strand (leading strand) in green with a Peptide Nucleic Acid probe and Alexa 488 and the telomeric C strand (lagging strand) in red with a Peptide Nucleic Acid probe and Alexa 546. Prior to their harvest the cells have been treated with siRNAs targeting RTEL1. RTEL1 is a helicase that is essential for telomere replication, and lack of the protein leads to stalled forks at telomeres and telomere breakage. This can be seen by individual telomeres that appear as more than one dot, as highlighted in the images. Airyscan resolves multiple telomere dots, thereby allowing an accurate quantification of telomere replication problems. Sample: Courtesy of J. Karlseder, Molecular and Cell Biology Laboratory; J. Fitzpatrick, Waite Advanced Biophotonics Core, Salk Institute for Biological Studies, La Jolla, USA.

ZEISS LSM 880 at Work

- › In Brief
- › The Advantages
- › **The Applications**
- › The System
- › Technology and Details
- › Service

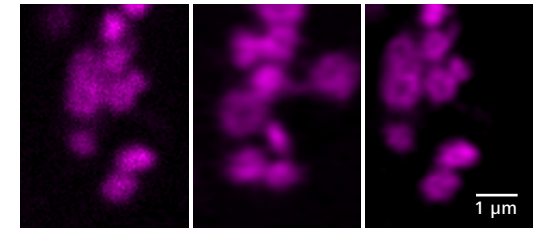
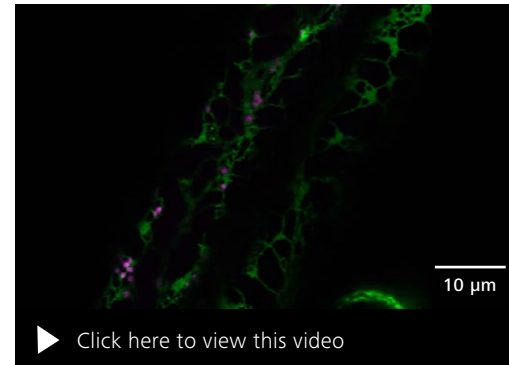
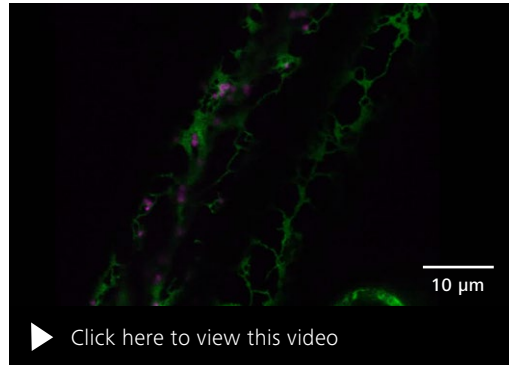

Arabidopsis root. Green: endoplasmatic reticulum labelled with GFP, magenta: Golgi labelled with RFP. Left: confocal GaAsP detection, right: Airyscan in Fast mode. Courtesy of C. Hawes, Oxford Brookes University, UK

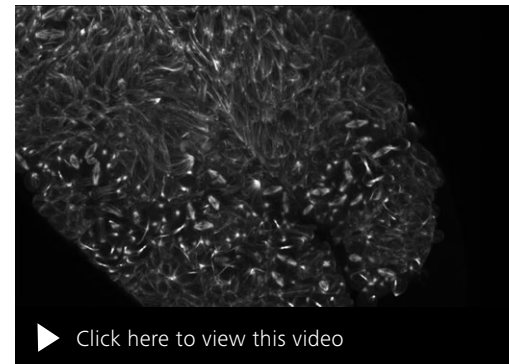

Drosophila embryo, maximum intensity projection. Microtubules labelled with GFP. Left: z-stack with 55 slices. Imaged for 203 min at 3 min interval. Right: same embryo imaged at higher magnification. Z-stack with 117 slices, imaged for 75 min at 3 min interval. Courtesy of B. Erdi, Max F. Perutz Laboratories, University of Vienna, Austria

ZEISS LSM 880 at Work

- › In Brief
- › The Advantages
- › **The Applications**
- › The System
- › Technology and Details
- › Service

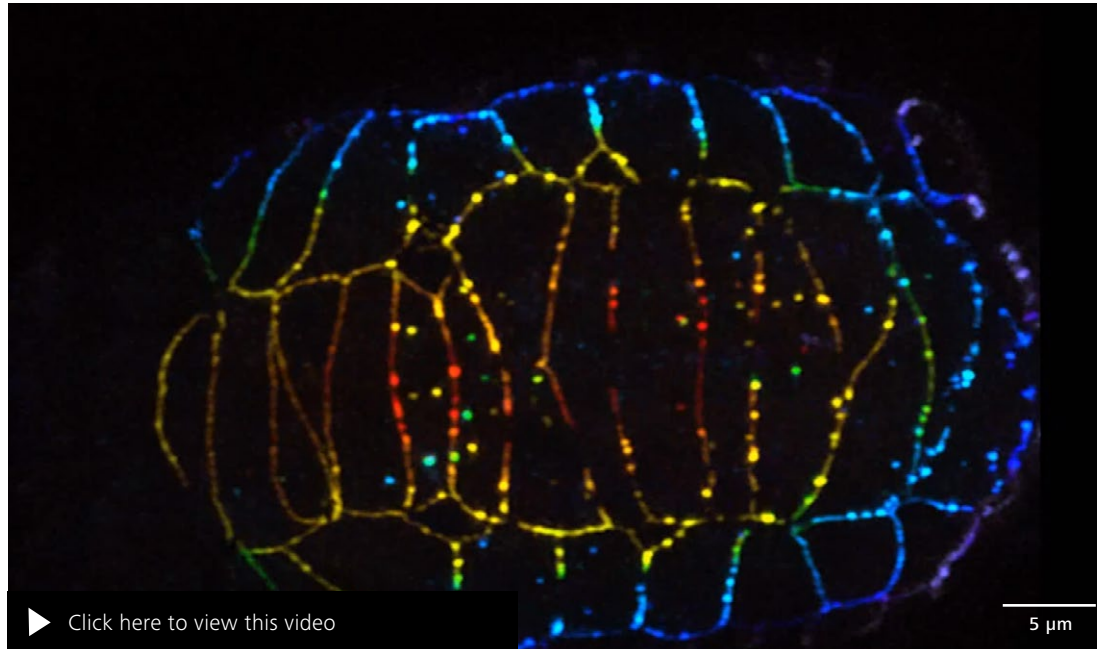

C. elegans embryo. Adherens junction protein labelled with GFP. Maximum intensity projection of a z-stack with 100 slices. Imaged for 120 min at 5 min interval. Courtesy of L. Cochella, Research Institute of Molecular Pathology (IMP), Vienna, Austria

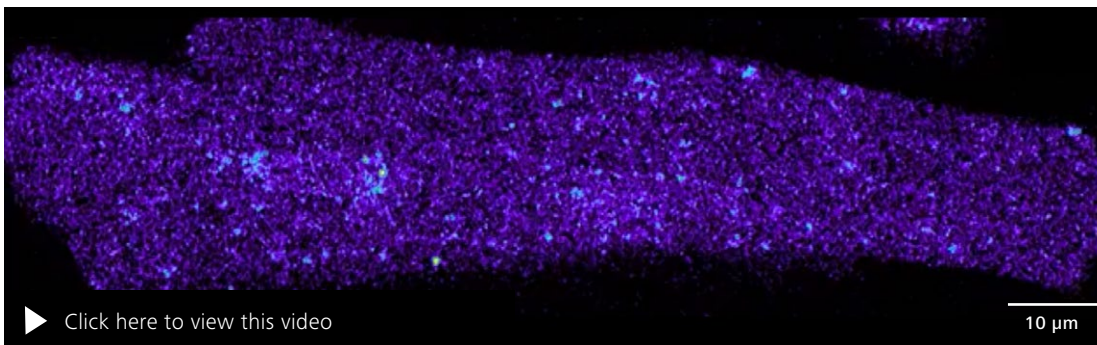

Calcium sparks labeled with Fluo 4 imaged in Cardiomyocytes with 50 frames per second. Airyscan in Fast mode. Courtesy of P. Robison, B. Prosser, University of Pennsylvania, USA

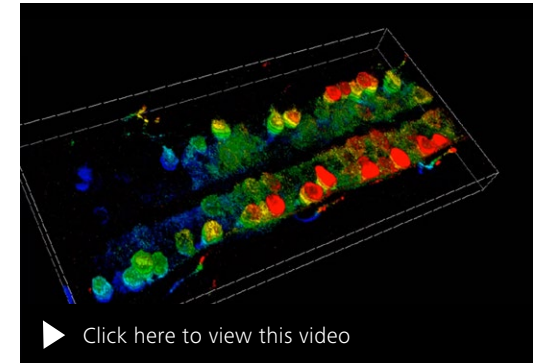

Calcium imaging of Zebra fish spine. GCaMP5, 920 nm excitation, 9 z-slices over 18 μm . Airyscan in Fast NLO mode. Sample: courtesy of D. Friedmann, UC Berkeley, USA

ZEISS LSM 880: Your Flexible Choice of Components

- › In Brief
- › The Advantages
- › The Applications
- › **The System**
- › Technology and Details
- › Service



1 Microscope

- Inverted stand: Axio Observer
- Upright stand: Axio Examiner, Axio Imager
- Port for coupling of ELYRA
- Camera port
- Manual or motorized stages
- Incubation solutions
- Fast Z piezo inserts
- Definite Focus

2 Objectives

- C-APOCHROMAT
- Plan-APOCHROMAT
- W Plan-APOCHROMAT, Clr Plan-APOCHROMAT, Clr Plan-NEOFLUAR
- LCI Plan-APOCHROMAT

3 Illumination

- UV laser: 355 nm, 405 nm
- VIS laser: 440 nm, 458 nm, 488 nm, 514 nm, 543 nm, 561 nm, 594 nm, 633 nm
- NIR laser for multiphoton imaging: Ti:Sa, OPO*, InSight DeepSee*, Discovery*

4 Detection

- 3 or 34 descanned spectral channels (GaAsP and/or multialkali PMT)
- Airyscan detector with optional Fast module
- 2 additional GaAsP channels (BiG.2)
- Up to 6 non-descanned GaAsP detectors
- Up to 12 non-descanned GaAsP or PMT detectors total
- Transmitted light detector (T-PMT)

5 Software

- ZEN, recommended modules: Tiles & Positions, Experiment Designer, FRAP, FRET, RICS, FCS, Deconvolution, 3Dxl Viewer – powered by arivis®

(* available upon request)

ZEISS LSM 880: System Overview

- › In Brief
- › The Advantages
- › The Applications
- › **The System**
- › Technology and Details
- › Service

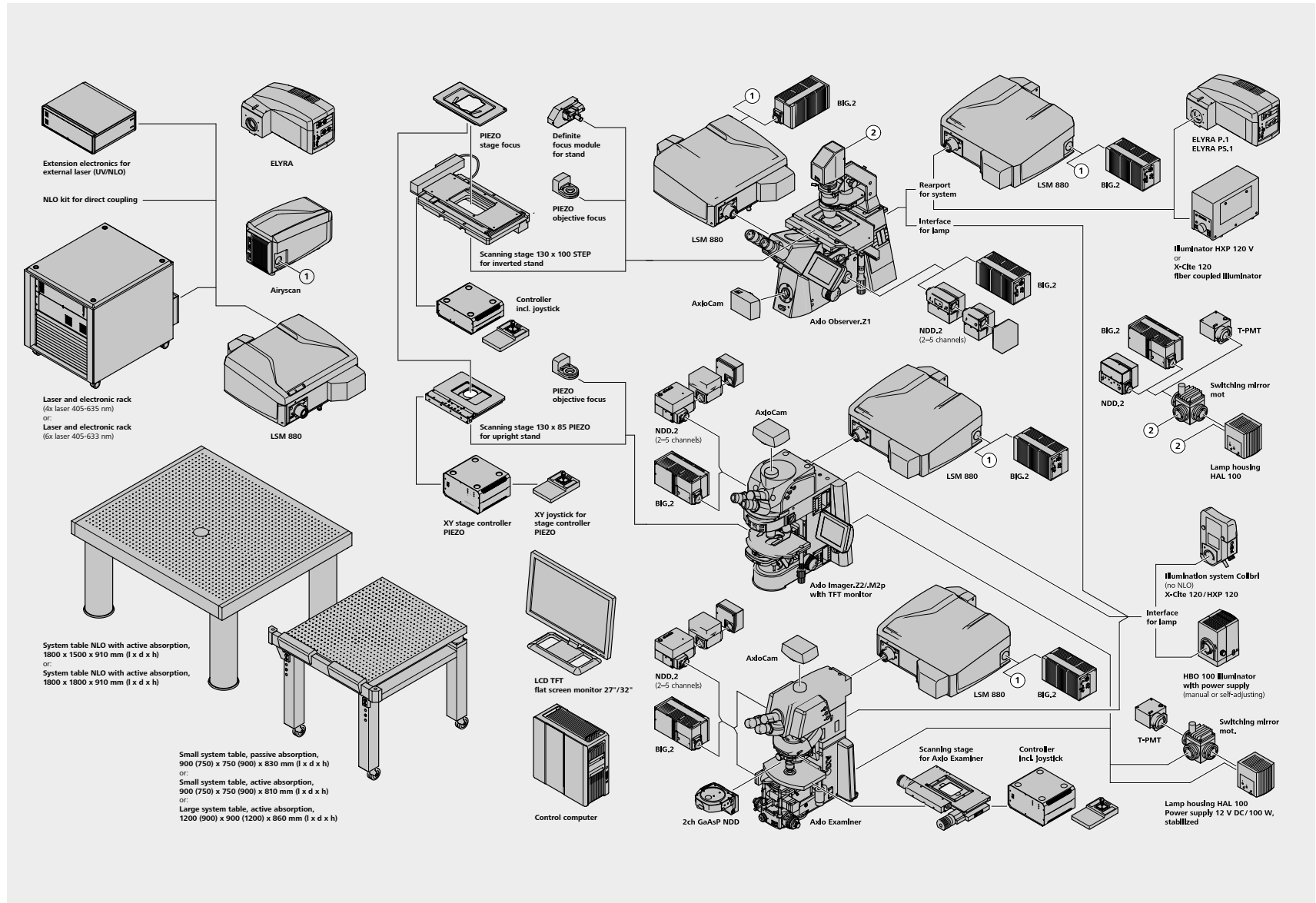

Technical Specifications

- › In Brief
- › The Advantages
- › The Applications
- › The System
- › **Technology and Details**
- › Service

LSM 880 on Small System Table.

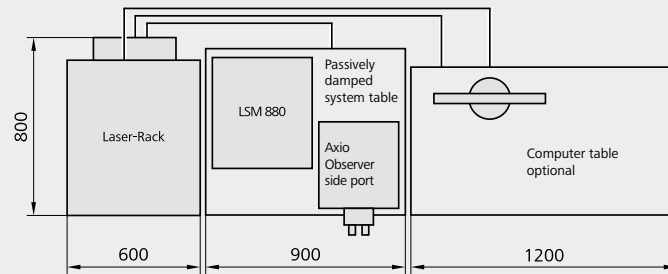

LSM 880 with Airyscan on Large System Table.

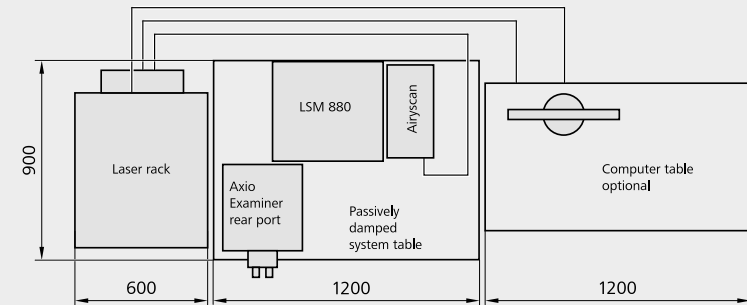
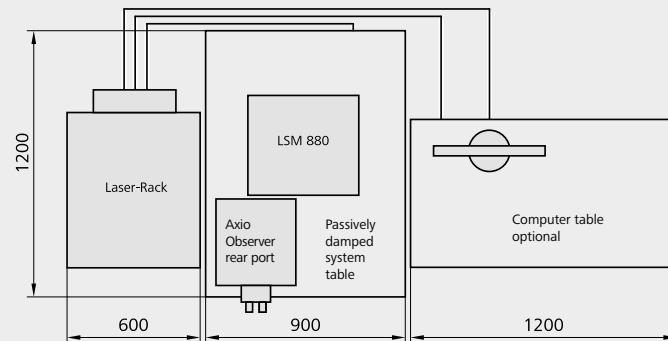
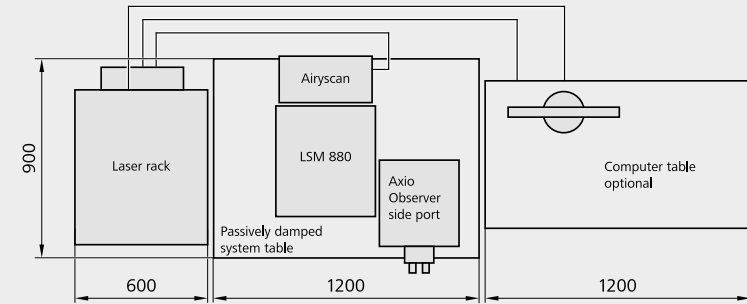

Technical Specifications

- › In Brief
- › The Advantages
- › The Applications
- › The System
- › **Technology and Details**
- › Service

LSM 880 Equipped with Two Photon Laser (NLO) for Single Stand.

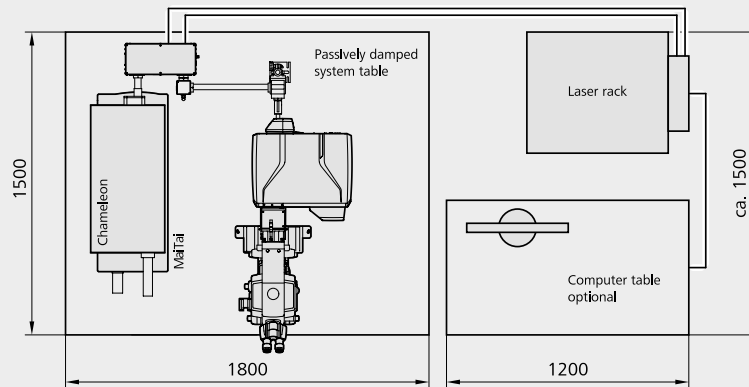

LSM 880 Equipped with Two Photon Laser (NLO) for Dual Stand.

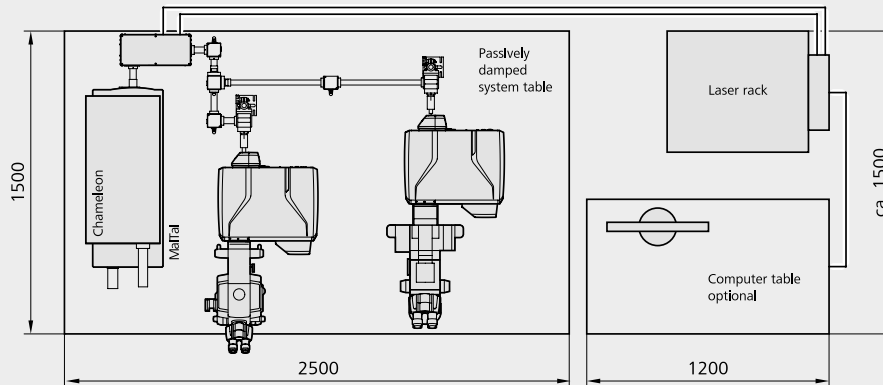

Technical Specifications

- › In Brief
- › The Advantages
- › The Applications
- › The System
- › **Technology and Details**
- › Service

Physical Dimensions	Length (cm)	Width (cm)	Height (cm)	Weight (kg)
Small passively damped system table	90	75	77	80
Small actively damped system table	90	75	77	90
Large actively damped system table	120	90	77	120
Active anti-vibration table (NLO) for Mai Tai Laser or Chameleon	180	150	75	200
Active anti-vibration table (NLO) for two-microscope configuration	250	150	75	400
Scanning Module LSM 880	50	45	22	27
Microscope	50	35	50	20
Electronic rack with laser units	80	60	65	80
Plug-in unit external laser	70	55	25	10
Laser module UV	80	60	45	40
Airyscan	40	20	24	12
Fiber optic cable, UV	200			
Fiber optic cable, VIS	250			
Cables	250			

Microscopes

Stands	Upright: Axio Imager.Z2, Axio Examiner.Z1 Inverse: Axio Observer.Z1 with side port or rear port
Z Drive	Smallest increment Axio Imager.Z2: <25 nm; Axio Observer.Z1: <25 nm; Axio Examiner: <30 nm; fast piezo objective or stage focus available; Definite Focus for Axio Observer.Z1
XY Stage (optional)	Motorized XY scanning stage, for Mark & Find function (XYZ) as well as Tile Scan (Mosaic Scan); smallest increment of 1 µm (Axio Observer.Z1), 0.2 µm (Axio Imager.Z2) or 0.8 µm (Axio Examiner.Z1)

Technical Specifications

- › In Brief
- › The Advantages
- › The Applications
- › The System
- › **Technology and Details**
- › Service

Scanning Module	
Scanner	Two independent, galvanometric scanning mirrors with ultrashort line and frame flyback
Scanning Resolution	4 × 1 to 8192 × 8192 pixels, also for multiple channels, continuously adjustable
Scanning Speed	19 × 2 speed levels; up to 13 images/sec. with 512 × 512 pixels (max. 430 images/sec. 512 × 16), up to 6875 lines/sec. In Fast Airyscan mode: 13×2 speed levels, up to 19 images/sec. with 512×512 (max. 27 images/sec. 480×480, or 6 images/sec. 1024×1024)
Scanning Zoom	0.6× to 40×; digitally adjustable in increments of 0.1 (Axio Examiner: 0.67× to 40×)
Scanning Rotation	Can be rotated freely (360 degrees), adjustable in increments of one degree, freely adjustable XY offset
Scanning Field	20 mm field diagonal (max. 18 mm for Axio Examiner) in the intermediate image plane, with full pupil illumination
Pinholes	Master pinhole with preset size and position; can be adjusted as desired for multitasking and short wavelengths (such as 405 nm)
Beam Path	Exchangeable Twin Gate beamsplitter with up to 100 combinations of excitation wavelengths and outstanding laser line suppression; manual interface port for external detection modules (such as BiG.2, Airyscan, third party detectors, internal detection with spectral signal separation and signal recycling loop for compensation of polarization effects)
Detection Options	
Detectors	3 or 34 spectral detection channels, GaAsP and/or multi-alkali PMT (QE 45% typical for GaAsP) 2 additional GaAsP detection channels (BiG.2) Airyscan detector (32 channels GaAsP), delivers resolution up to 140 nm lateral, 400 nm axial; in Fast mode: 145/180 nm lateral, 450 nm axial Up to 12 non-descanned detection channels (PMT and/or GaAsP) Transmitted light detector (PMT)
Spectral Detection	3 or 34 simultaneous, confocal reflected-light channels, GaAsP and/or PMT based freely adjustable spectral detection area (resolution down to 3 nm)
Data Depth	8 bit, 12 bit or 16 bit available; up to 35 channels simultaneously detectable
Real-Time Electronics	Microscope, laser, scanning module and additional accessory control; data acquisition and synchronization management through real-time electronics; oversampling read-out logic; ability to evaluate data online during image acquisition

Technical Specifications

- › In Brief
- › The Advantages
- › The Applications
- › The System
- › **Technology and Details**
- › Service

ZEN Imaging Software

System Configurations	Workspace to conveniently configure all of the motorized functions of the scanning module, laser and microscope; save and restore application configurations (Re-use)
System Self-Test	Calibration and testing tool to automatically test and calibrate the system
Recording Modes, Smart Setup	Spot, Line/Spline, Frame, Tiles, Z Stack, Lambda Stack, Time Series and all combinations (XYZ, lambda, t), online calculation and visualization of ratio images, average and summation (by line/image, adjustable), Step Scan (for higher image frame rates); quick set up of imaging conditions using Smart Setup by simply selecting the labelling dye
Crop Function	Easily select scanning areas (simultaneously select zoom, offset, rotation)
Real ROI Scan, Spline Scan	Scans of up to 99 designated ROIs (regions of interest) as desired and pixel-by-pixel laser blanking; scan along a freely defined line
ROI Bleaching	Localized bleaching in up to 99 bleach ROIs for applications such as FRAP (fluorescence recovery after photobleaching) or uncaging; use of different speeds for bleaching and imaging, use of different laser lines for different ROIs
Multitracking	Rapidly change excitation lines when recording multiple fluorescences for the purpose of minimizing signal crosstalk and increasing dynamic range
Fast Acquisition	Fast mode scan with 4x parallelisation in Y-direction, detection by Airyscan module
Lambda Scan	Parallel or sequential acquisition of image stacks with spectral information for every pixel
Linear Unmixing	Acquisition of crosstalk-free, multiple fluorescence images using simultaneous excitation; online or offline and automatic or interactive unmixing; advanced unmixing logic with indication of reliability
Visualization	XY, orthogonal (XY, XZ, YZ), Cut (3D section); 2.5D for time series of line scans, projections (maximum intensity); animations; Depth coding (inverse colors), brightness, gamma and contrast settings; color table selection and modification (LUT), character functions
Image Analysis and Operations	Colocalization and histogram analysis with individual parameters, number & brightness analysis, profile measurement along user-defined lines, measurement of lengths, angles, areas, intensities and much more; operations: addition, subtraction, multiplication, division, ratio, shift, filters (low-pass, median, high-pass, etc., also user-definable)
Image Management	Features for managing images and the corresponding imaging parameters; multiprint feature; streaming of acquisition data for online processing of large data sets

Technical Specifications

- › In Brief
- › The Advantages
- › The Applications
- › The System
- › **Technology and Details**
- › Service

Optional Software	
3Dxl Viewer powered by arivis	Rapid 3D and 4D reconstructions and animations (available modes: shadow projections, transparency projection, surface rendering)
Deconvolution	3D, GPU based Cuda image restoration based on calculated point-spread functions (modes: nearest neighbor, maximum likelihood, constrained iterative)
ROI-HDR	Imaging mode: High Dynamic Range, intelligent, local improvement of the dynamic signal range, user-selectable gain and laser power
Physiology	Comprehensive evaluation software for online and offline calibration of ion concentrations
FRET	Acquisition of FRET (Förster resonance energy transfer) image data with subsequent evaluation; Acceptor Photobleaching and Sensitized Emission methods supported
FRAP efficiency analysis	Acquisition of FRAP (fluorescence recovery after photobleaching) experiments with subsequent evaluation of intensity kinetics
RICS Image Correlation	Single molecule imaging and analysis using multi-alkali or GaAsP PMT detectors (publ. v. Gratton)
Experiment Designer	Definition of customized imaging configurations and procedures
Macro Environment	VBA Macro recording and editing

Technical Specifications

- › In Brief
- › The Advantages
- › The Applications
- › The System
- › **Technology and Details**
- › Service

Lasers	
Laser Insert RGB (pigtailed; 458, 488, 514, 543, 561, 594, 633 nm)	Single-mode polarization preserving fiber Laser beam attenuation for all lasers by VIS-AOTF Ar laser (458, 488, 514 nm, 25 or 35 mW) HeNe laser (543 nm, 1 mW) DPSS laser (561 nm, 20 mW) HeNe laser (594 nm, 2 mW) HeNe laser (633 nm, 5 mW)
Laser Insert V (pigtailed; 405, 440 nm)	Single-mode polarization preserving fiber Diode Laser pulsed/cw (405 nm, 30 mW) cw mode max power ca. 15 mW at fiber out range 0.6 – 15 mW w/o attenuator, attenuation by a factor of 25 pulsed mode repetition rate 20 – 50 – 80 MHz mean power: @20 MHz – ca. 0.2 mW; @50 MHz – ca. 0.5 mW; @80 MHz – ca. 0.8 mW peak power: 50 – 300 mW pulse width: 50 – 90 ps jitter <20 ps Diode Laser pulsed/cw (440 nm, 25 mW) cw mode max power ca. 15 mW at fiber out range 0.6 – 15 mW w/o attenuator, attenuation by a factor of 25 pulsed mode repetition rate 20 – 50 – 80 MHz mean power: @20 MHz – ca. 0.1 mW; @50 MHz – ca. 0.25 mW; @80 MHz – ca. 0.4 mW peak power: 50 – 300 mW pulse width: 50 – 90 ps jitter <20 ps

Technical Specifications

- › In Brief
- › The Advantages
- › The Applications
- › The System
- › **Technology and Details**
- › Service

Lasers

Laser Module UV (355 nm)	Single-mode polarization preserving fiber
	Laser beam attenuation by AOM
	DPSS laser (355 nm, 60 mW)

Power Requirements

LSM 880 has a main power supply cord and plug, either CEE red (3/N/PE 400/230V/16A), or NEMA L 14-30P (2/N/Ground 120/240V/30A), and the matching mains socket outlet. The mains socket outlet must be equipped with a fuse having minimum tripping characteristic C according to IEC/EN 60898.

Line Voltage	3/N/PE 400/230 V AC (±10 %)	2/N/Ground 240/120 V AC
Line Frequency	50...60 Hz	50...60 Hz

ZEISS LSM 880 incl. VIS Laser

Max. Current	3 phases at 16 A	2 phases at 25 A
Power	Phase 1 = 600 VA max.	Phase 1 = 800 VA max.
	Phase 2 = 500 VA max.	Phase 2 = 1600VA max.
	Phase 3 = 1500 VA max.	
Power Consumption	2100 VA max.	2100 VA max.

Multiphoton Laser

Power Consumption

Ti:Sa laser	800 VA max.	800 VA max.
Heat emission without Ti:Sa	2000 W max.	2000 W max.

EMC test

according to DIN EN 61326-1 (05/2010)

1. Noise emission according to CISPR 11 / DIN EN 55011 (04/2011)
2. Noise immunity according to table 2 (industrial sector)

Technical Specifications

- › In Brief
- › The Advantages
- › The Applications
- › The System
- › **Technology and Details**
- › Service

Environmental Requirements

For operation the system has to be placed in a closed room.

1. Operation, specified performance	T = 22 °C ± 3 °C without interruption (24 h a day independently whether system is operated or switched-off) It has to be ensured that the air-flow of the air-conditioning is not directed at the system.
2. Operation, reduced performance	T = 15 °C to 35 °C, any conditions different from item 1. and 5.
3. Storage, less than 16 h	T = -20 °C to 55 °C
4. Storage, less than 6 h	T = -20 °C to 55 °C
5. Temperature gradient	±0.5 °C/h
6. Warm up time	1 h, for high-precision and/or long-term measurements ≥3 h
7. Relative humidity	<65% at 30 °C
8. Operation altitude	max. 2000 m
9. Loss of heat (without Ti:Sa)	2 kW
10. Vibrations under operation conditions (with system table)	5 µm pp at 5 Hz 10 µm pp at 10 Hz 10 µm pp at 20 Hz
11. Shipping shock (LSM 880 box)	10 g

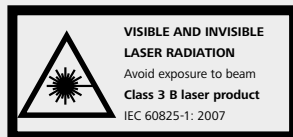

LSM 880 meets the requirements according to IEC 60825-1:2007

Count on Service in the True Sense of the Word

- › In Brief
- › The Advantages
- › The Applications
- › The System
- › Technology and Details
- › **Service**

Because the ZEISS microscope system is one of your most important tools, we make sure it is always ready to perform. What's more, we'll see to it that you are employing all the options that get the best from your microscope. You can choose from a range of service products, each delivered by highly qualified ZEISS specialists who will support you long beyond the purchase of your system. Our aim is to enable you to experience those special moments that inspire your work.

Repair. Maintain. Optimize.

Attain maximum uptime with your microscope. A ZEISS Protect Service Agreement lets you budget for operating costs, all the while reducing costly downtime and achieving the best results through the improved performance of your system. Choose from service agreements designed to give you a range of options and control levels. We'll work with you to select the service program that addresses your system needs and usage requirements, in line with your organization's standard practices.

Our service on-demand also brings you distinct advantages. ZEISS service staff will analyze issues at hand and resolve them – whether using remote maintenance software or working on site.

Enhance Your Microscope System.

Your ZEISS microscope system is designed for a variety of updates: open interfaces allow you to maintain a high technological level at all times. As a result you'll work more efficiently now, while extending the productive lifetime of your microscope as new update possibilities come on stream.



Profit from the optimized performance of your microscope system with services from ZEISS – now and for years to come.

>> www.zeiss.com/microservice



Carl Zeiss Microscopy GmbH
07745 Jena, Germany
microscopy@zeiss.com
www.zeiss.com/sm880

