

Decipher the Family Tree of the Buzzies!

By James Kosmopoulos

Vocabulary words: evolution, organism, cladogram, common ancestor, cladistics, character, branch, root.

Buzzies are a group of friendly bugs that live inside the Carl R. Woese Institute for Genomic Biology (IGB). The scientists working there have noticed that some buzzies look different than other buzzies. Some biologists at the IGB study evolution. Evolution is the study of how a life form (called an organism) changes over time. The biologists say that the reason why the buzzies look intrdifferent is because of changes that happened in their evolution.

A family tree that shows how organisms are related to one other through evolution is called a cladogram. Biologists make cladograms because it can help them answer questions about how different organisms have evolved to be the way they are. Much like family trees for people, cladograms show relationships between organisms by connecting lines from existing organisms to ancestors that they descended from. Biologists call an ancestor that connects the relationship of multiple organisms a common ancestor. Sometimes, a cladogram will even show how one organism's common ancestor is related to a different organism's common ancestor by connecting lines from them to an even *older* common ancestor.

Biologists make cladograms through a process called cladistics. Cladistics is a trial-and-error way of comparing organisms to one another based on their characters, or what they look like. Organisms that share a lot of characters are thought to be closely related, meaning that they share a recent common ancestor. Organisms that don't share as many characters are thought to be distantly related, meaning that you have to look farther back in a cladogram to find their common ancestor.

Like a tree, cladograms contain branches and roots. Branches are lines that follow the descent to an organism on the cladogram. Roots are areas where branches meet each other (see the example below), and they represent a common ancestor that joins two organisms.

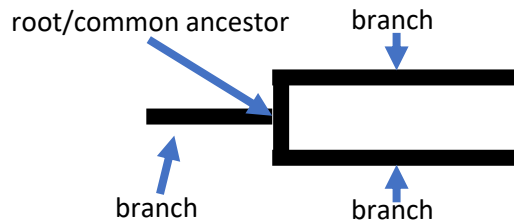

On the next page, you should see 5 buzzies that are found at the IGB. **Cut out these buzzies to use for later.**

If you look at the sheet that says “**Cladogram Template**” you will see an example of a blank cladogram that you will use to show the relationship between the buzzies. Empty **blue boxes** represent a type of buzzie found in the IGB. Empty **red boxes** with arrows represent a *new* character appearing in the buzzies. **Using the cladogram template, your job is to write in the characters inside the red boxes and to place the buzzies you cut out into the correct blue boxes based on their relationship to one another.** Use a pencil with an eraser to

write in the characters in case you need to change what you wrote. Even though you might be able to guess, you do not need to find out what the common ancestors of the buzzies at each root look like.

If a **red box** points to a branch on the cladogram, that means that all the buzzies branching from the *right* of the **red box** should have whatever character you write inside that box. Buzzies that are branching from the *left* of the **red box** should *not* have whatever character you write inside that box (see the example below). Not all branches will have a **red box** indicating a change!

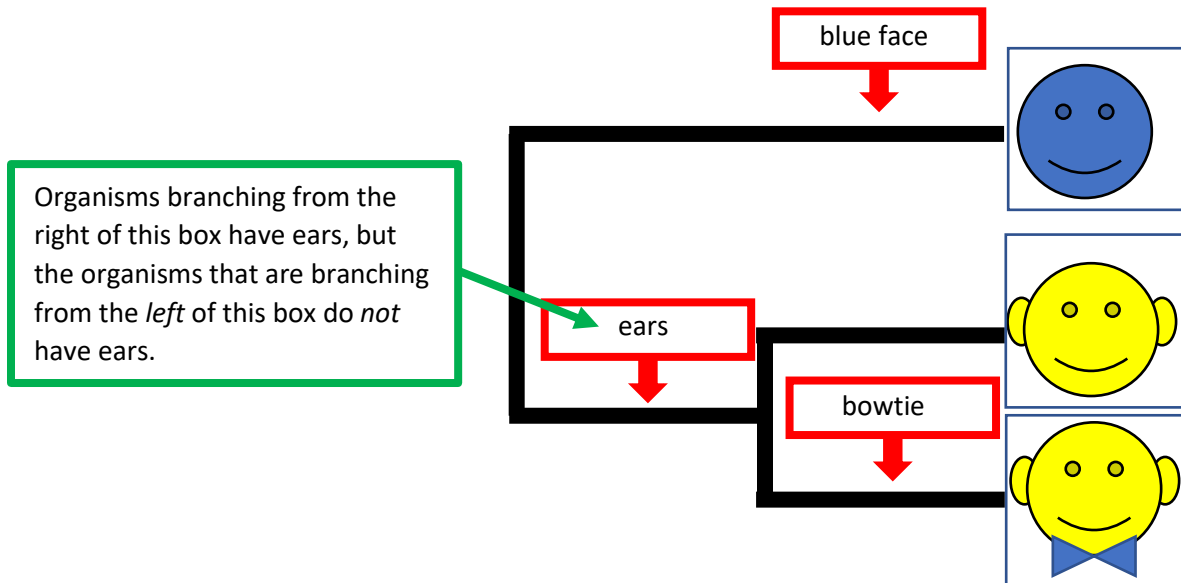

There are **two** possible cladograms that can be made to accurately show how all the buzzies are related by evolution. They are shown in the answer keys, don't look until you think you've got the right answer. Try as many times as you can, even biologists that study evolution whose job it is to make cladograms must try many times before they get a cladogram that makes the most sense!

After you complete your cladogram, take a photo and share it with us if you like. [Tweet](#) it at us! [Gram](#) it our way! Put it on [Facebook](#)! Tag us with #couchreach (that's outreach from your couch)!

[\(Missed yesterday's activity? Check out our archive\)](#)

Cut out the images of the buzzies below and begin building a cladogram that shows how they are all related through evolution:

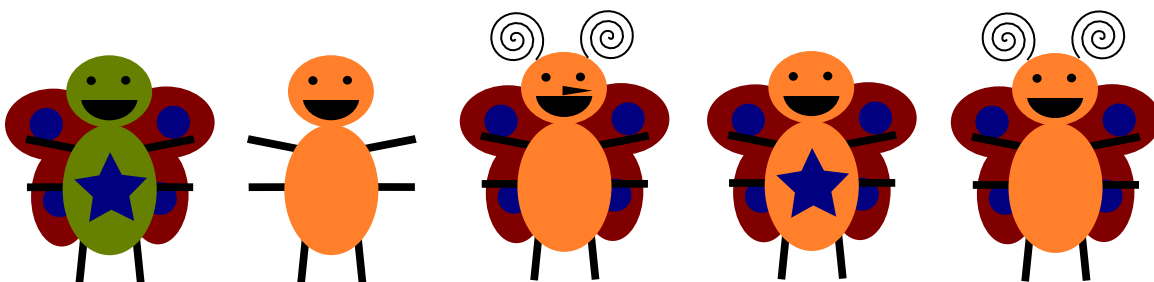

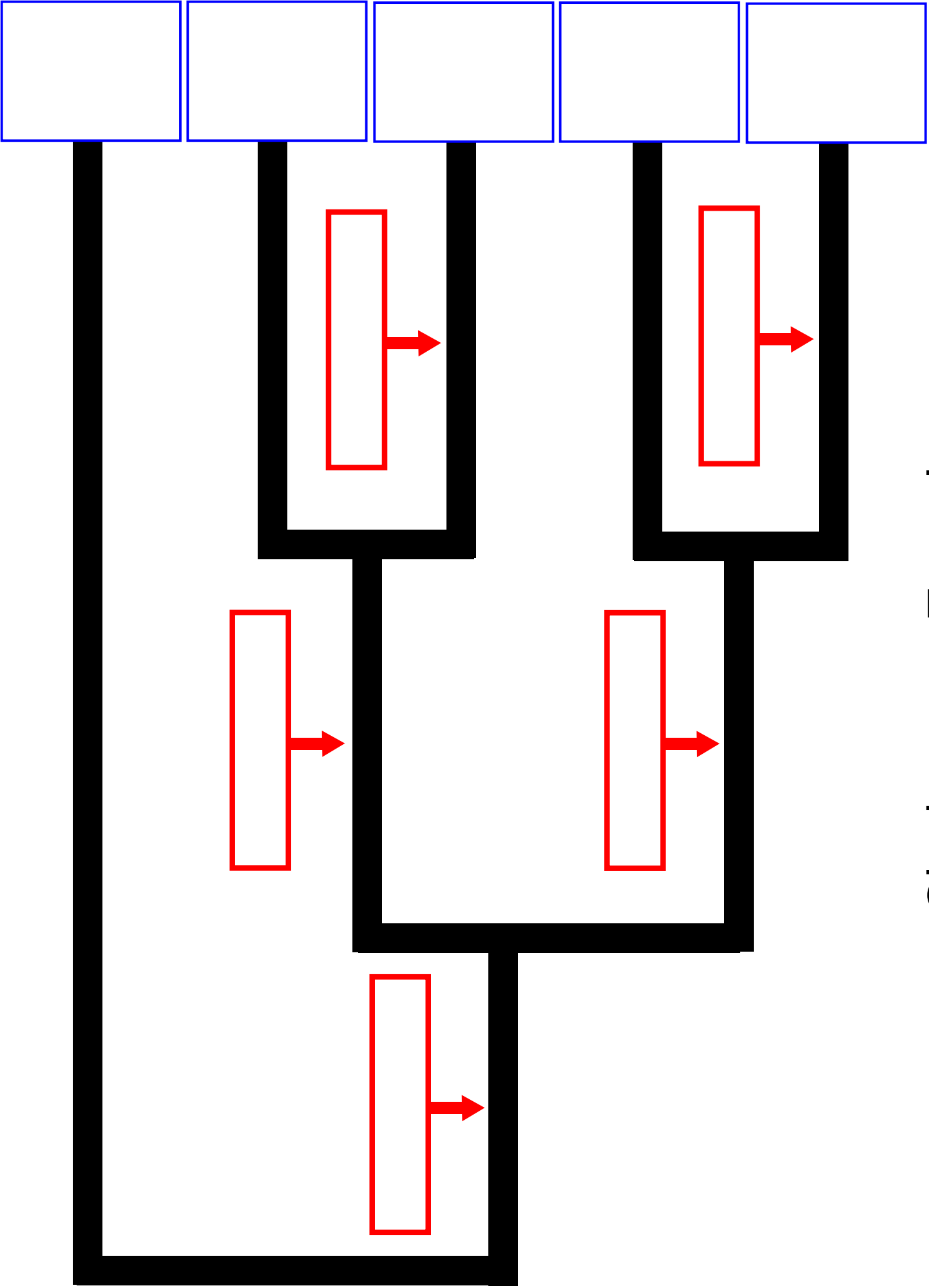

Cladogram Template

Answer key

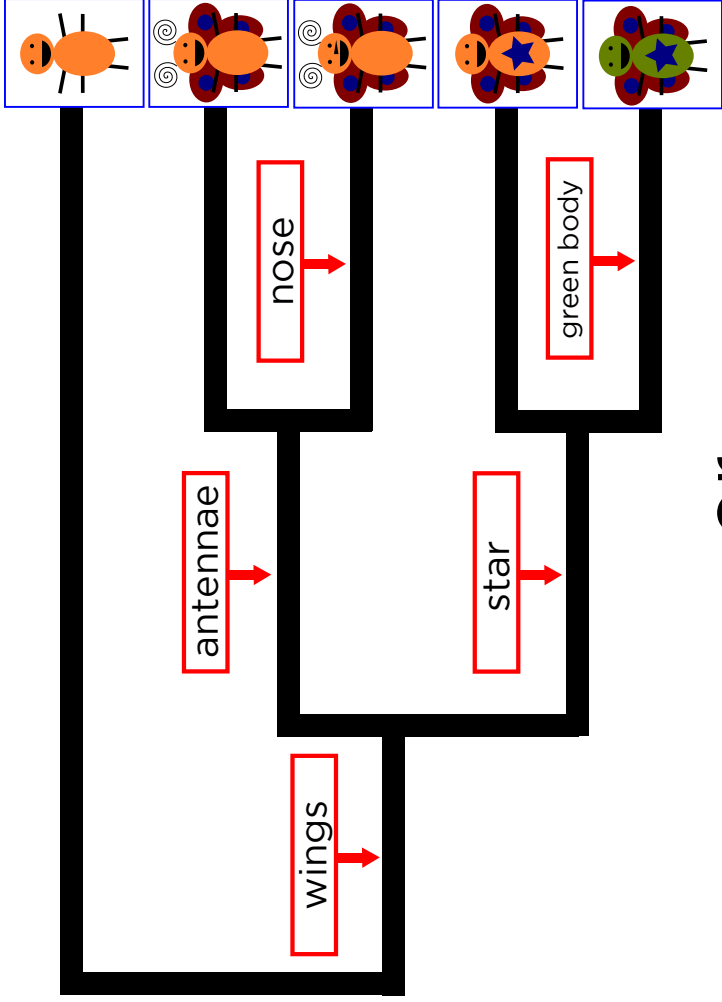

-or-

